

MWLD | Single-Zone | Wall Only



Cold Climate | High Efficiency Heat Pump Outdoor Units | R-32 | 60 Hz

RESIDENTIAL / COMMERCIAL
PRODUCT SPECIFICATIONS (EHB)

SEER2 up to 25.0

HSPF2 up to 11.0

0.75 to 2 Tons

Cooling Capacity - 9,000 to 22,000 Btuh

Heating Capacity - 9,000 to 22,000 Btuh

Heating down to -22°F (-30°C)



MWLD018S6S and MWLD024S6S
Heat Pump Outdoor Units



MWMDS6 Wall-Mount Units
with Wireless Remote Control
(furnished)



MWLD009S6S and MWLD012S6S
Heat Pump Outdoor Units
(MWLD015S6S not shown)



MODEL NUMBER IDENTIFICATION

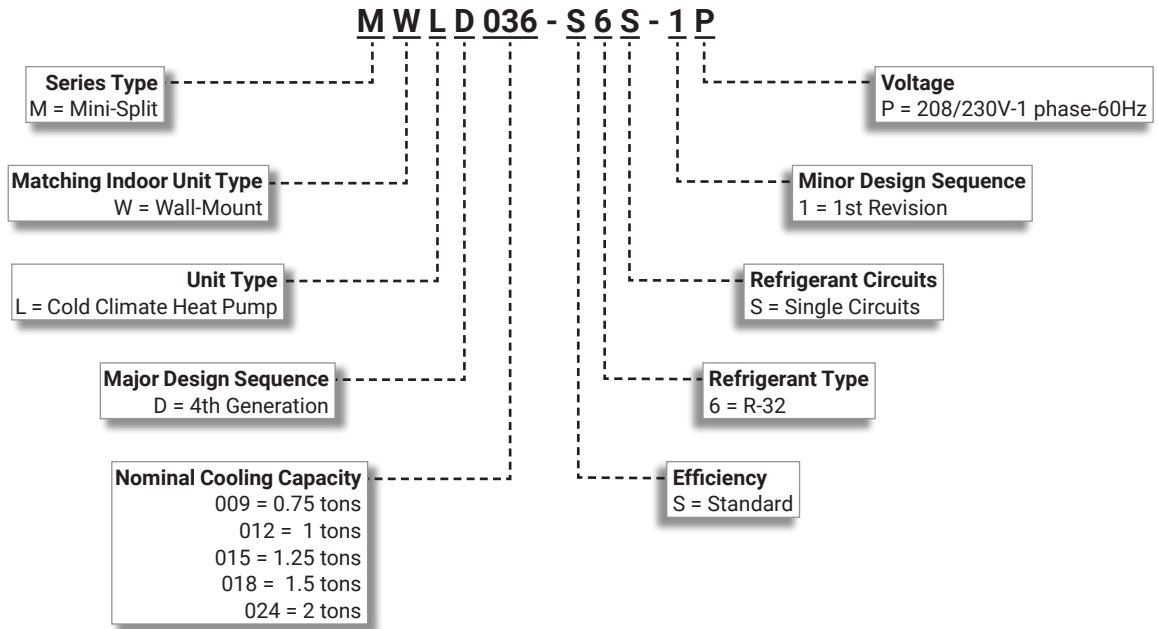

CONTENTS

AHRI System Matches	13
Approvals And Warranty	4
Capacity Correction	27
Dimensions	19
- Center Of Gravity	22
- Unit	19
Features	4
- Indoor Units Overview	6
- Outdoor Units	4
Installation Clearances	23
- Multiple Outdoor Units	24
- Single Outdoor Unit	23
Mobile Apps	7
Model Number Identification	2
Operation Range	26
Optional Accessories - Order Separately	12
Sound Data	25
Specifications	10
- 009-015	10
- 018-024	11
System Components	3

SYSTEM COMPONENTS



Wireless Remote Control
(Included with all indoor units)

Also available:
Advanced Wired Control
Touchscreen Controller
Thermostat Adaptor
(use with any 24V thermostat)



MWMD Wall-Mounted
Non-Ducted Indoor Unit



Single zone heat pumps offer a wide range of capacities and indoor unit configurations. One outdoor unit is matched to one indoor unit.

MWLD009 thru 012 Outdoor Unit
(not shown - MWLD015, 018 and 024)

APPROVALS AND WARRANTY

APPROVALS

- AHRI Standard 210/240-2023 certified with Addenda 1 and 2
- ENERGY STAR® certified units are designed to use less energy, help save money on utility bills, and help protect the environment
- Rated According to U.S. Department of Energy (DOE) test procedures
- Outdoor units and components UL and CEC bonded for grounding to meet safety standards for servicing
- ETL certified for the U.S. and Canada

WARRANTY

- Compressor - Limited seven years
- All other covered components
 - Limited five years in all applications
- Accessories and controls - Limited one year

NOTE - Refer to Lennox Basic Limited Warranty at www.Lennox.com for additional details.

FEATURES

APPLICATIONS

- Cold climate heating down to -22°F (-30°C)
- 0.75 through 2 ton
- Single phase power supply (208/230V)
- Outdoor unit powers indoor unit
- Sound levels as low as 45 dBA
- Ductless mini-split systems provide a wide range of capacities and applications and provide an alternative when a ducted system is impractical or cost prohibitive
- Units shipped completely factory assembled, internally piped, and wired

NOTE - Outdoor unit is designed for outdoor location only.

REFRIGERATION SYSTEM

R-32 Refrigerant

- Low GWP (Global Warming Potential)
- Zero ODP (Ozone Depletion Potential)
- Low Toxicity/Lower Flammability - A2L
- Unit is factory pre-charged

Outdoor Coil

- Aluminum fins fitted to copper tubes

Outdoor Fan

- Direct drive fan moves large air volumes uniformly through entire outdoor coil for high refrigeration capacity
- Fan guard furnished

OUTDOOR UNITS

Refrigerant Line Connections, Service Valve

- Flare connection lines are located on side of unit cabinet
- Fully serviceable brass service valve prevents corrosion and provides access to refrigerant system

COMPRESSOR

Variable Frequency Rotary Compressor

- Compressor features high efficiency operation
- Balanced for reduced vibration and quiet operation
- Brushless DC motor uses powerful Neodymium magnets, which are approximately 15-20 times stronger than ferrite magnets used in conventional AC compressors

Compressor Crankcase Heater

- Protects against liquid refrigerant migration that can occur during low ambient operation

CONTROLS**DC Inverter Control**

- Provides continuous operation, while adjusting capacity according to room temperature
- The accurate sensing of cooling loads prevents frequent changes in capacity and ensures efficient, economical operation

Inverter Module Protection

- Protects against differences in current, voltage and temperature
- Displays code on the indoor unit indicating a need for servicing

Outdoor Unit Microprocessor

- Electronic expansion valve control
- Automatic compressor timed-off protection (3 minutes)
- Temperature sensor
- LEDs on control display error codes and assist in troubleshooting
- 4-Way reversing valve control

Electronic Expansion Valve

- Furnished on all models

Compressor Overcurrent Protection

- Overcurrent protection can result due to any of the following:
 - Ambient temperature is too high
 - Locked rotor on the compressor
 - Outdoor air is blocked or restricted

Condenser High Temperature Protection

- Condenser high temperature can occur due to any of the following conditions:
 - High outdoor ambient
 - Outdoor fan blocked
 - Outdoor coil blocked
- The outdoor coil thermistor continuously monitors the temperature and communicates with the microprocessor
- Depending on the temperature measured, the compressor will be allowed to increase the frequency if needed to meet the load or is forced to run at the current or reduced frequency
- If the temperature becomes excessively high the compressor will be de-energized

Compressor Discharge Temperature Protection

- The compressor discharge line thermistor continuously monitors the temperature and communicates with the microprocessor
- Depending on the temperature measured, the compressor will be allowed to increase the frequency to meet the load or is forced to run at the current or reduced frequency
- If the temperature becomes excessively high, the compressor will be de-energized

Voltage Protection

- Protects unit from low or high voltage fluctuations

Terminal Strip

- Furnished for easy wiring connections

Defrost Control

- Defrost cycle is automatically enabled if there is a build-up of frost on the outdoor coil
- Outdoor fan operation is terminated during the defrost cycle
- Indoor fan changes to ultra low speed during the defrost cycle to help bring warm refrigerant back to the outdoor coil to assist during defrost operation
- Defrost LED is lit on the indoor unit panel on the front cover during a defrost cycle

Reversing Valve

- 4-way interchange reversing valve effects a rapid change in direction of refrigerant flow resulting in quick changeover from cooling to heating and vice versa
- Valve operates on pressure differential between outdoor unit and indoor unit of the system

CABINET

- Constructed of heavy gauge steel
- Tabs on unit base allow secure mounting to slab
- Condensate drain outlets furnished on unit base

NOTE - Drain must be field furnished.

- Pan heater prevents ice build-up in the bottom of the unit during heating operation
- Access cover for power and control wiring connections
- Access cover for service valves

WALL-MOUNTED INDOOR UNITS

- Eliminates ductwork by utilizing refrigerant piping to preserve space in the attic or closet
- Compact and unobtrusive design also blends seamlessly into any space
- Low-sound
- Swing louver angles to 90°
- **Calm Air Feature** - When louvers are closed, thousands of micro holes in panel provide a dispersed, gentle flow of air
- Unit installs horizontally on a vertical wall
- Vacuum or washable reusable filter media
- Flare connections
- Wall plate furnished for installation
- Wireless remote controller furnished

NOTE - See the MWMD Product Specifications.

MOBILE APPS

Lennox Home App



- The free Lennox Home App is available for use on smartphones.
- The Lennox Home App integrates with the SmartThings app to control Mini-Split system modes and fan operation



SmartThings App



- SmartThings is a free app that uses Wi-Fi to connect smart devices built on the Matter protocol, regardless of the company that makes them
- Users can remotely regulate temperature, adjust settings, receive real-time updates about system performance and energy usage, as well as troubleshoot solutions if service is needed
- Quickly and easily connect, automate and manage your smart home devices through SmartThings
- SmartThings is compatible with hundreds of smart home brands
- With SmartThings, you can connect, monitor and control multiple smart home devices quicker and easier
- Connect smart TVs, smart appliances, smart speakers and brands like Samsung, Ring, Nest and Philips Hue - all from one free app
- Control your smart devices using voice assistant skills including Alexa, Bixby and Google Assistant

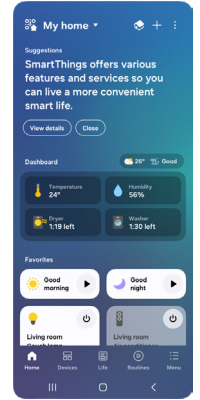

OPTIONAL ACCESSORIES - ORDER SEPARATELY

OUTDOOR UNITS

(See Optional Accessories Table on page 12 for Selection)

- Equipment Pads
- Equipment Stands
- Hail Guards
- Wind Baffles
- Wall Brackets
- Line Sets
- Control Wiring
- Disconnects
- Whips

SPEEDICHANNEL™ SYSTEM



- SpeediChannel™ is a channel system covers system line sets
- Two-part system has a base and a cover
- Base is fastened to a wall or ceiling with plastic clips (SpeediClip™) that snap into a channel already molded into the base
- Cover fits on top of the base
- Manufactured from rigid PVC, which is UL rated and resistant to UV light
- System is a natural color that closely matches typical mini-split outdoor units
- Can be painted as desired to match any wall color

Typical Application

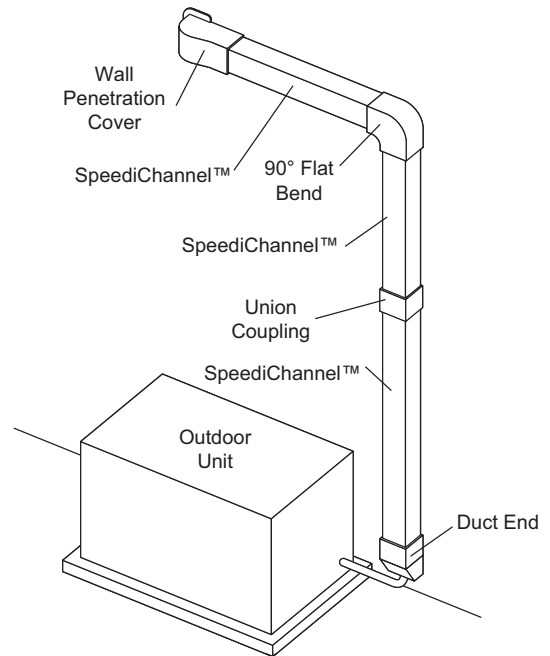

OPTIONAL ACCESSORIES - ORDER SEPARATELY

SPEEDICHANNEL™ SYSTEM (continued)

SpeediChannel™ Starter Kit

- The starter kit includes (1) Coupling, (1) Wall Penetration, (1) Inside Elbow, (1) Long Radius Flat Bend, (10) Speediclips™, (10) 11 in. Cable Ties, and (1) SpeediChannel Instruction Booklet

Duct End

- Duct Ends are used to terminate a run of SpeediChannel™ to a small opening just large enough for the line set and condensate drain line to pass through



Flat Wall Escutcheon

- Flat Wall Escutcheons are used to cover a rough opening in a soffit, wall, or ceiling penetration



- One side of the escutcheon is flat to allow for a SpeediChannel™ to run along a wall and to penetrate through an adjacent wall or ceiling
- This is the most common type of wall penetration
- Furnished in two parts, the escutcheon easily snaps onto the SpeediChannel™

Flex Joint

- A Flex Joint is an accordion-style piece of SpeediChannel™
- The flex joint can be extremely flexible when routing a SpeediChannel™ system around an obstacle
- Each joint is 20 in. long and can be combined together for longer flex runs
- The flex joint does not require the use of a union coupling
- The flex joint slides tightly inside the SpeediChannel™ system

T-Joint

- T-Joints are used for creating a tee connection between three pieces of SpeediChannel™
- Each tee is individually packed and furnished with stainless steel screws

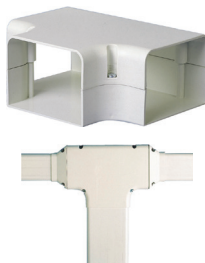

Union Coupling

- Union Couplings are used for joining two pieces of SpeediChannel™
- Each coupling is individually packed and furnished with stainless steel screws



Wall Penetration Cover

- Wall penetration covers are used to transition from the SpeediChannel™ system to a through wall penetration
- Wall covers are designed to allow for easy installation, even after the line set has been installed
- A hooking and fastening arrangement allows for quick installation
- Each wall cover is individually packed, and furnished with stainless steel screws to attach the wall cover to the base
- Three screws are necessary to fasten the wall cover to the wall construction, regardless of the type of installed system



45° and 90° Flat Bend Elbows

- 45° Flat Bends are used to route the SpeediChannel™ around obstacles
- Each bend is individually packed and furnished with stainless steel screws

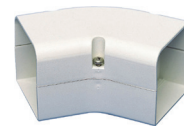

45°



90°

90° Inside Elbow

- 90° Inside Elbows are used to route the SpeediChannel™ around an inside corner
- Each elbow is individually packed and furnished with stainless steel screws

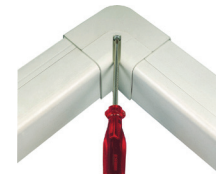

Mount Block White Qty. (2) 14 in. and (2) 36 in.

- Mount Blocks are used as mounting bases when outdoor units must be bolted down
- End caps (for aesthetics) come furnished with mounting bolts
- Maximum load capacity is 900 pounds per mounting block
- Installation temperatures range from -4°F to 140°F
- Mount blocks fit all mini-split outdoor units with a sliding rail feature



SPECIFICATIONS
009-015

Model		MWLD009S6S	MWLD012S6S	MWLD015S6S
Tons		0.75	1	1.25
Ambient Temperature Range - °F	Cooling	0 to 115	0 to 115	0 to 115
	Heating	-22 to 75	-22 to 75	-22 to 75
Connections	Liquid (flare) - in.	1/4	1/4	1/4
	Gas (flare) - in.	3/8	3/8	1/2
	Maximum pipe length for all rooms - ft	66	66	98
	Maximum height difference between indoor and outdoor units - ft	49	49	66
Refrigerant	Charge furnished (R-32)	2 lbs. 2 oz.	2 lbs. 2 oz.	3 lbs. 2 oz.
Compressor	Type	BLDC Rotary	BLDC Rotary	BLDC Rotary
	Output (kW)	4.09	4.09	4.68
	Refrigerant oil type	POE	POE	POE
	Initial oil charge - oz	11.8	11.8	15.2
Outdoor Fan	Number and Type	1 Propeller	1 Propeller	1 Propeller
	cfm	1560	1560	2013
Outdoor Fan Motor	Type	BLDC	BLDC	BLDC
	Output (W)	40	40	125
Outdoor Coil	Type	Aluminum Fin/Copper Tube		
Sound Data (dBA)	Cooling	45	46	48
Shipping Data	Net	71	71	108
	Shipping	77	77	116
ELECTRICAL DATA				
Line voltage data (Volts-Phase-Hz)		208/230-1-60	208/230-1-60	208/230-1-60
	¹ Maximum Overcurrent Protection (MOCP) amps	20	20	30
	² Minimum circuit ampacity (MCA)	12	12.5	21

NOTE - Extremes of operating range are plus and minus 10% of line voltage.

¹ HACR type circuit breaker or fuse.

² Refer to National or Canadian Electrical Code manual to determine wire, fuse and disconnect size requirements.

SPECIFICATIONS
018-024

Model		MWLD018S6S	MWLD024S6S
Tons		1.5	2
Ambient Temperature Range - °F	Cooling	0 to 115	0 to 115
	Heating	-22 to 75	-22 to 75
Connections	Liquid (flare) - in.	1/4	1/4
	Gas (flare) - in.	1/2	5/8
	Maximum pipe length for all rooms - ft	98	98
	Maximum height difference between indoor and outdoor units - ft	66	66
Refrigerant	Charge furnished (R-32)	4 lbs. 8 oz.	4 lbs. 8 oz.
Compressor	Type	BLDC Rotary	BLDC Rotary
	Output (kW)	8.02	8.02
	Refrigerant oil type	POE	POE
	Initial oil charge - oz	23.7	23.7
Outdoor Fan	Number and Type	1 Propeller	1 Propeller
	cfm	2825	2825
Outdoor Fan Motor	Type	BLDC	BLDC
	Output (W)	125	125
Outdoor Coil	Type	Aluminum Fin/Copper Tube	
Sound Data (dBA)	Cooling	51	54
Shipping Data	Net	150	150
	Shipping	162	162
ELECTRICAL DATA			
Line voltage data (Volts-Phase-Hz)		208/230-1-60	208/230-1-60
¹ Maximum Overcurrent Protection (MOCP) amps		30	30
² Minimum circuit ampacity (MCA)		21	21

NOTE - Extremes of operating range are plus and minus 10% of line voltage.

¹ HACR type circuit breaker or fuse.

² Refer to National or Canadian Electrical Code manual to determine wire, fuse and disconnect size requirements.

OPTIONAL ACCESSORIES - ORDER SEPARATELY

Description	Order Number	Size				
		009	012	015	018	024
OUTDOOR UNIT						
Line Sets	1/4 x 3/8 3/8 25 ft.	90X53	•	•		
Liquid x Gas OD Insulation Thickness Length	1/4 x 3/8 3/8 50 ft.	X0258	•	•		
	1/4 x 1/2 3/8 25 ft.	90X52			•	•
	1/4 x 1/2 3/8 50 ft.	X0259			•	•
	1/4 x 5/8 3/8 25 ft.	90X51				•
	1/4 x 5/8 3/8 50 ft.	X0260				•
Hail Guards	Side	38U95	•	•		
	Back	38U89	•	•		
	Side	38U96			•	
	Back	38U90			•	
	Side	38U97				•
	Back	38U91				•
Wind Baffles	Front	38V18	•	•		
	Back	38V12	•	•		
	Front	38V20			•	
	Back	38V14			•	
	Front	38V17				•
	Back	38V11				•
Equipment Pads	18 x 38 x 3 in. direct mount, gray plastic	Y5014	•	•	•	•
	24 x 48 x 3 in. black	28V63	•	•	•	•
Equipment Stands	12 in. height, adjustable 34 to 40 in. white	Y8240	•	•	•	•
	18 in. height, adjustable 34 to 40 in. white	Y8236	•	•	•	•
	10 in. height, 24 x 36 in. gray	Y8397	•	•	•	•
	18 in. height, 30 x 40 in. gray	28U18	•	•	•	•
Wall Brackets	Wall unit installation support tool	Y6999	•	•	•	•
	30 x 16 in. (D x H) gray (qty 2)	X1727	•	•	•	•
25 x 18-3/8 in. (D x H), adjustable width 6 to 34 in. SS, wind/hurricane rated		Y8239	•	•	•	N/A
Control Wiring	Five conductor cable, 250 ft. (14/3, 16/2)	29F41	•	•	•	•
	Weather-tight cable connector (qty 1)	29F45	•	•	•	•
Disconnects	30A Pull-out Fusible	Y9684	•	•	•	•
	60A Pull-out Fusible	Y9685	•	•	•	•
	60A Pull-out Non-Fusible	Y9686	•	•	•	•
Whips	Metal Fittings 1/2 in. x 6 ft., 10 AWG	29P54	•	•	•	•
	Metal Fittings 3/4 in. x 6 ft., 8 AWG	27P44	•	•	•	•
	Plastic Fittings 1/2 in. x 6 ft., 10 AWG	36P48	•	•	•	•
	Plastic Fittings 3/4 in. x 6 ft., 8 AWG	46N89	•	•	•	•
SPEEDICHANNEL™ SYSTEM						
SpeediChannel™ Starter Kit - 4 in.		Y7950	•	•	•	•
SpeediChannel - 4 in. x 6-1/2 ft. (qty. 6)		Y3388	•	•	•	•
Union Coupling - 4 in.		Y3389	•	•	•	•
90° Flat Bend Elbow - 4 in.		Y3390	•	•	•	•
90° Inside Elbow - 4 in.		Y3391	•	•	•	•
90° Outside Elbow - 4 in.		Y6074	•	•	•	•
45° Flat Bend Elbow - 4 in.		Y3392	•	•	•	•
Flex Joint - 4 in.		Y3393	•	•	•	•
T-Joint - 4 in.		Y3394	•	•	•	•
Duct End - 4 in.		Y3395	•	•	•	•
Flat Wall Escutcheon - 4 in.		Y3396	•	•	•	•
Wall Penetration Cover - 4 in.		Y3399	•	•	•	•
Mount Block (White) Qty, 2 - 14 in.		Y3397	•	•	•	•
Mount Block (White) Qty, 2 - 36 in.		Y3398	•	•	•	•

AHRI SYSTEM MATCHES

Outdoor Unit	Indoor Unit	Cooling Capacity	SEER2	EER2	Heating Capacity	HSPF2 (IV)	AHRI Reference Number	Energy Star Certified?
MWLD009S6S-1P	MWMD009S6-1P	9000	25	16.35	9000	10.5	216411305	Yes
MWLD012S6S-1P	MWMD012S6-1P	12000	24	14.1	12000	10.5	216411306	Yes
MWLD015S6S-1P	MWMD015S6-1P	15000	23	14.55	15000	11	216411307	Yes
MWLD018S6S-1P	MWMD018S6-1P	18500	21	13.2	18500	9.7	216411308	Yes
MWLD024S6S-1P	MWMD024S6-1P	22000	20	12.8	22000	9.5	216411309	Yes

Ratings are AHRI certified to AHRI Standard 210/240-2023;

- Cooling Ratings - 95°F wet bulb/75°F dry bulb outdoor air temperature and 80°F dry bulb/67°F wet bulb entering indoor coil air.
- High Temperature Heating Ratings - 47°F dry bulb/43°F wet bulb outdoor air temperature and 70°F dry bulb/60°F wet bulb entering indoor coil air.
- Low Temperature Heating Ratings - 17°F dry bulb/15°F wet bulb outdoor air temperature and 70°F dry bulb/60°F wet bulb entering indoor coil air.

To convert HSPF from Region IV to Region V - Divide by 1.15.

COOLING CAPACITY

MWLD009S6S + MWMD009S6

Outdoor Temp. °F (Dry Bulb)	Indoor Temperature - °F (Dry Bulb / Wet Bulb)																							
	64 / 53			68 / 57			72 / 61			77 / 64			80 / 67			82 / 70			86 / 72			90 / 75		
	TC MBH	SHC MBH	PI kW	TC MBH	SHC MBH	PI kW	TC MBH	SHC MBH	PI kW	TC MBH	SHC MBH	PI kW	TC MBH	SHC MBH	PI kW	TC MBH	SHC MBH	PI kW	TC MBH	SHC MBH	PI kW	TC MBH	SHC MBH	PI kW
-0.4	10.9	8.8	0.5	10.5	8.4	0.5	10.5	8.4	0.6	11.1	8.9	0.7	11.6	9.3	0.7	12.0	9.6	0.7	13.0	10.4	0.8	14.0	11.2	0.7
32	11.2	9.0	0.4	10.9	8.7	0.4	11.0	8.8	0.5	11.6	9.3	0.6	12.2	9.7	0.6	12.6	10.1	0.6	13.6	10.9	0.6	14.7	11.7	0.6
50	11.6	9.3	0.3	11.2	9.0	0.4	11.3	9.1	0.5	12.0	9.6	0.6	12.6	10.0	0.6	13.0	10.4	0.6	14.0	11.2	0.6	15.1	12.0	0.6
68	11.7	9.4	0.4	11.4	9.1	0.4	11.5	9.2	0.5	12.1	9.7	0.6	12.7	10.1	0.7	13.1	10.5	0.7	14.1	11.3	0.7	15.1	12.1	0.6
85	11.4	9.2	0.4	11.1	8.9	0.5	11.2	8.9	0.6	11.8	9.4	0.7	12.3	9.8	0.8	12.7	10.2	0.8	13.7	10.9	0.8	14.7	11.7	0.8
95	11.0	8.8	0.5	10.6	8.5	0.6	10.7	8.5	0.7	11.2	9.0	0.8	9.0	7.2	0.6	12.2	9.8	0.9	13.1	10.5	0.9	14.1	11.3	0.9
104	10.4	8.3	0.6	10.0	8.0	0.7	10.0	8.0	0.8	10.6	8.4	0.9	11.1	8.9	1.0	11.5	9.2	1.0	12.3	9.9	1.0	13.3	10.6	1.0
110	9.8	7.9	0.7	9.4	7.5	0.8	9.5	7.6	0.9	10.0	8.0	1.0	10.4	8.4	1.1	10.8	8.7	1.1	11.7	9.4	1.1	12.6	10.1	1.1
115	9.3	7.5	0.7	8.9	7.1	0.8	8.9	7.1	1.0	9.4	7.5	1.1	9.8	7.9	1.2	10.2	8.2	1.2	11.1	8.9	1.2	11.9	9.6	1.2

TC = Total Capacity

SHC = Sensible Heating Capacity

PI - Power Input

HEATING CAPACITY

MWLD009S6S + MWMD009S6

Outdoor Temp. °F (Dry Bulb)	Indoor Temperature - °F (Dry Bulb)											
	60		64		68		70		72		75	
	TC MBH	PI kW	TC MBH	PI kW	TC MBH	PI kW	TC MBH	PI kW	TC MBH	PI kW	TC MBH	PI kW
-22	6.8	1.1	6.7	1.1	6.6	1.1	6.6	1.2	6.5	1.2	6.5	1.4
-5	11.5	1.7	11.4	1.6	11.3	1.6	11.2	1.7	11.1	1.8	11.0	2.0
-4	11.7	1.7	11.6	1.6	11.5	1.7	11.4	1.7	11.3	1.8	11.2	2.0
0	12.4	1.7	12.3	1.7	12.2	1.7	12.1	1.8	12.0	1.9	11.8	2.0
5	13.2	1.8	13.1	1.7	13.0	1.8	12.9	1.8	12.8	1.9	12.5	2.1
14	14.2	1.8	14.2	1.7	14.0	1.8	13.9	1.8	13.7	1.9	13.4	2.1
23	14.9	1.7	14.8	1.7	14.6	1.7	14.5	1.8	14.3	1.9	14.0	2.0
32	15.4	1.6	15.3	1.6	15.0	1.6	14.9	1.7	14.6	1.8	14.2	1.9
41	15.7	1.4	15.6	1.4	15.3	1.5	15.1	1.5	14.9	1.6	14.4	1.8
47	15.9	1.3	15.8	1.3	15.5	1.4	11.0	0.7	15.0	1.5	14.5	1.7
55	16.2	1.2	16.1	1.2	15.8	1.3	15.5	1.3	15.2	1.4	14.6	1.5
65	16.9	1.1	16.7	1.1	16.4	1.2	16.1	1.2	15.7	1.3	15.0	1.4
75	17.9	1.0	17.8	1.0	17.3	1.1	17.0	1.2	16.6	1.2	15.8	1.3

TC = Total Capacity

PI - Power Input

COOLING CAPACITY

MWLD012S6S + MWMD012S6

Outdoor Temp. °F (Dry Bulb)	Indoor Temperature - °F (Dry Bulb / Wet Bulb)																							
	64 / 53			68 / 57			72 / 61			77 / 64			80 / 67			82 / 70			86 / 72			90 / 75		
	TC MBH	SHC MBH	PI kW	TC MBH	SHC MBH	PI kW	TC MBH	SHC MBH	PI kW	TC MBH	SHC MBH	PI kW	TC MBH	SHC MBH	PI kW	TC MBH	SHC MBH	PI kW	TC MBH	SHC MBH	PI kW	TC MBH	SHC MBH	PI kW
-0.4	11.5	9.4	0.5	11.7	9.3	0.6	12.0	9.5	0.7	12.5	9.9	0.8	12.9	10.3	0.9	13.3	10.6	0.9	14.2	11.4	0.9	15.5	12.4	0.9
32	11.1	9.1	0.3	11.4	9.1	0.5	11.7	9.3	0.6	12.3	9.8	0.7	12.8	10.3	0.7	13.2	10.6	0.7	14.2	11.4	0.7	15.6	12.4	0.7
50	11.8	9.7	0.3	12.2	9.7	0.5	12.5	9.9	0.6	13.1	10.5	0.7	13.6	10.9	0.7	14.1	11.3	0.7	15.1	12.1	0.7	16.4	13.1	0.7
68	12.6	10.3	0.4	12.9	10.3	0.6	13.2	10.5	0.7	13.9	11.0	0.8	14.4	11.5	0.9	14.8	11.8	0.9	15.8	12.7	0.9	17.1	13.7	0.8
85	12.7	10.4	0.5	13.0	10.4	0.7	13.4	10.6	0.9	14.0	11.1	1.0	14.4	11.6	1.1	14.8	11.9	1.1	15.8	12.7	1.1	17.2	13.7	1.1
95	12.4	10.1	0.6	12.7	10.1	0.9	13.0	10.3	1.0	13.6	10.8	1.2	12.0	9.6	0.9	14.4	11.6	1.2	15.4	12.4	1.2	16.7	13.4	1.2
104	11.7	9.6	0.7	12.0	9.6	1.0	12.3	9.7	1.2	12.8	10.2	1.3	13.3	10.6	1.4	13.7	10.9	1.4	14.6	11.7	1.4	15.9	12.7	1.4
110	11.0	9.0	0.8	11.3	9.0	1.1	11.6	9.2	1.3	12.1	9.6	1.4	12.5	10.0	1.5	12.9	10.3	1.5	13.8	11.1	1.5	15.1	12.1	1.5
115	10.3	8.4	0.9	10.5	8.4	1.1	10.8	8.6	1.3	11.3	9.0	1.5	11.7	9.4	1.6	12.1	9.7	1.6	13.0	10.5	1.6	14.3	11.4	1.6

TC = Total Capacity

SHC = Sensible Heating Capacity

PI - Power Input

HEATING CAPACITY

MWLD012S6S + MWMD012S6

Outdoor Temp. °F (Dry Bulb)	Indoor Temperature - °F (Dry Bulb)											
	61		64		68		70		72		75	
	TC MBH	PI kW	TC MBH	PI kW	TC MBH	PI kW	TC MBH	PI kW	TC MBH	PI kW	TC MBH	PI kW
-22	6.7	1.2	6.3	1.1	6.2	1.1	6.2	1.2	6.3	1.3	6.4	1.5
-5	12.8	1.9	12.6	1.8	12.4	1.8	12.3	1.9	12.2	2.0	12.0	2.2
-4	13.1	1.9	12.8	1.8	12.6	1.9	12.5	1.9	12.4	2.0	12.2	2.2
0	14.0	2.0	13.8	1.9	13.6	2.0	13.5	2.0	13.3	2.1	13.0	2.3
5	14.9	2.0	14.8	2.0	14.6	2.0	14.4	2.1	14.2	2.2	13.9	2.4
14	16.1	2.0	16.1	2.0	15.8	2.0	15.7	2.1	15.4	2.2	15.0	2.4
23	16.7	1.9	16.8	1.9	16.6	2.0	16.4	2.0	16.1	2.1	15.5	2.3
32	16.9	1.8	17.1	1.8	16.9	1.8	16.7	1.9	16.4	2.0	15.7	2.2
41	16.7	1.6	17.1	1.6	17.0	1.7	16.8	1.7	16.4	1.8	15.6	2.0
47	16.5	1.5	17.0	1.5	17.0	1.5	12.0	0.8	16.4	1.7	15.5	1.8
55	16.2	1.3	16.8	1.3	16.9	1.4	16.7	1.4	16.3	1.5	15.4	1.7
65	15.8	1.1	16.7	1.1	16.9	1.2	16.7	1.3	16.3	1.3	15.3	1.5
75	15.7	1.0	16.8	1.1	17.1	1.1	16.9	1.2	16.5	1.2	15.5	1.3

TC = Total Capacity

PI - Power Input

COOLING CAPACITY

MWLD015S6S + MWMD015S6

Outdoor Temp. °F (Dry Bulb)	Indoor Temperature - °F (Dry Bulb / Wet Bulb)																							
	64 / 53			68 / 57			72 / 61			77 / 64			80 / 67			82 / 70			86 / 72			90 / 75		
	TC MBH	SHC MBH	PI kW	TC MBH	SHC MBH	PI kW	TC MBH	SHC MBH	PI kW	TC MBH	SHC MBH	PI kW	TC MBH	SHC MBH	PI kW	TC MBH	SHC MBH	PI kW	TC MBH	SHC MBH	PI kW	TC MBH	SHC MBH	PI kW
-0.4	13.1	11.3	0.9	14.4	11.4	0.9	15.3	12.0	0.9	16.7	12.5	1.0	17.3	13.3	1.0	18.1	12.9	1.0	19.2	13.3	1.0	20.4	13.3	1.0
32	13.5	11.7	0.9	14.8	11.8	0.9	15.8	12.4	0.9	17.2	12.9	0.9	17.8	13.7	1.0	18.7	13.3	1.0	19.8	13.7	1.0	21.0	13.8	1.0
50	13.9	11.8	0.8	15.1	11.9	0.8	16.1	12.5	0.9	17.6	12.9	0.9	18.2	13.7	0.9	19.0	13.3	0.9	20.1	13.7	0.9	21.3	13.7	0.9
68	14.3	11.9	0.8	15.4	12.0	0.8	16.5	12.5	0.8	17.9	12.9	0.8	18.6	13.7	0.9	19.3	13.3	0.9	20.4	13.6	0.9	21.5	13.6	0.9
85	15.7	13.0	1.4	17.1	13.1	1.5	18.3	13.7	1.5	20.0	14.2	1.5	20.8	15.1	1.5	21.6	14.7	1.5	22.9	15.0	1.6	24.3	15.1	1.6
95	16.7	13.7	1.9	18.3	13.8	1.9	19.6	14.5	1.9	21.4	15.0	2.0	15.0	12.0	1.0	23.2	15.6	2.0	24.6	16.0	2.0	26.0	16.0	2.0
104	15.5	12.7	2.1	17.0	12.9	2.1	18.2	13.5	2.1	19.9	14.0	2.2	20.6	14.8	2.2	21.5	14.5	2.2	22.8	14.9	2.2	24.2	14.9	2.2
110	14.8	12.1	2.2	16.1	12.2	2.2	17.3	12.8	2.2	18.9	13.3	2.3	19.6	14.1	2.3	20.4	13.7	2.3	21.7	14.1	2.4	23.0	14.2	2.4
115	15.2	12.2	0.6	16.2	12.2	0.7	17.4	12.7	0.7	18.8	13.0	0.7	19.7	13.9	0.7	20.2	13.3	0.7	21.3	13.6	0.8	22.2	13.4	0.8

TC = Total Capacity

SHC = Sensible Heating Capacity

PI - Power Input

HEATING CAPACITY

MWLD015S6S + MWMD015S6

Outdoor Temp. °F (Dry Bulb)	Indoor Temperature - °F (Dry Bulb)											
	61		64		68		70		72		75	
	TC MBH	PI kW	TC MBH	PI kW	TC MBH	PI kW	TC MBH	PI kW	TC MBH	PI kW	TC MBH	PI kW
-22	7.8	1.6	7.7	1.7	7.6	1.7	7.5	1.7	7.5	1.7	7.4	1.7
-5	16.1	2.1	15.8	2.2	15.6	2.2	15.5	2.2	15.5	2.2	15.2	2.3
-4	16.6	2.2	16.3	2.2	16.1	2.2	15.9	2.2	15.9	2.3	15.7	2.3
0	17.8	2.2	17.5	2.3	17.3	2.3	17.1	2.3	17.1	2.4	16.9	2.4
5	19.3	2.4	19.1	2.4	18.8	2.4	18.6	2.5	18.6	2.5	18.3	2.5
14	21.0	2.3	20.7	2.4	20.4	2.4	20.2	2.4	20.2	2.5	19.9	2.5
23	22.8	2.3	22.4	2.4	22.1	2.4	21.9	2.4	21.7	2.5	21.5	2.5
32	24.5	2.3	24.1	2.4	23.7	2.4	23.5	2.4	23.3	2.4	23.0	2.5
41	25.2	2.2	24.8	2.3	24.4	2.3	24.2	2.3	24.0	2.3	23.7	2.4
47	25.7	2.2	25.3	2.2	24.9	2.2	15.0	1.0	24.5	2.3	24.2	2.3
55	26.4	2.1	25.9	2.1	25.5	2.2	25.3	2.2	25.1	2.2	24.8	2.2
65	27.2	2.0	26.8	2.0	26.3	2.0	26.1	2.1	25.9	2.1	25.6	2.1
75	28.0	1.9	27.6	1.9	27.1	1.9	26.9	1.9	26.7	2.0	26.3	2.0

TC = Total Capacity

PI - Power Input

COOLING CAPACITY

MWLD018S6S + MWMD018S6

Outdoor Temp. °F (Dry Bulb)	Indoor Temperature - °F (Dry Bulb / Wet Bulb)																							
	64 / 53			68 / 57			72 / 61			77 / 64			80 / 67			82 / 70			86 / 72			90 / 75		
	TC MBH	SHC MBH	PI kW	TC MBH	SHC MBH	PI kW	TC MBH	SHC MBH	PI kW	TC MBH	SHC MBH	PI kW	TC MBH	SHC MBH	PI kW	TC MBH	SHC MBH	PI kW	TC MBH	SHC MBH	PI kW	TC MBH	SHC MBH	PI kW
-0.4	19.2	16.3	1.3	21.0	16.5	1.3	22.4	17.3	1.4	24.4	18.0	1.4	25.2	19.1	1.5	26.5	18.6	1.4	28.1	19.1	1.5	29.8	19.2	1.5
32	19.5	16.5	1.3	21.3	16.7	1.3	22.7	17.6	1.3	24.8	18.2	1.4	25.6	19.4	1.5	26.9	18.9	1.4	28.5	19.4	1.5	30.2	19.5	1.4
50	19.7	16.4	1.2	21.4	16.5	1.2	22.9	17.3	1.3	24.9	17.9	1.3	25.8	19.0	1.4	26.9	18.5	1.4	28.4	18.9	1.4	30.0	18.9	1.4
68	19.3	15.9	1.3	20.9	16.0	1.3	22.3	16.7	1.4	24.3	17.2	1.4	25.2	18.3	1.5	26.2	17.8	1.5	27.7	18.2	1.5	29.2	18.1	1.5
85	18.4	15.0	1.7	20.1	15.1	1.7	21.4	15.8	1.7	23.4	16.4	1.8	24.3	17.4	1.8	25.3	16.9	1.8	26.8	17.4	1.8	28.3	17.4	1.8
95	17.9	14.5	1.9	19.6	14.6	1.9	21.0	15.3	1.9	22.9	15.9	2.0	18.0	14.4	1.4	24.8	16.5	2.0	26.3	16.9	2.0	27.9	16.9	2.0
104	16.0	12.9	2.1	17.4	13.0	2.2	18.7	13.7	2.2	20.4	14.2	2.2	21.2	15.0	2.3	22.1	14.7	2.3	23.5	15.0	2.3	24.9	15.1	2.3
110	14.7	11.8	2.3	16.0	12.0	2.3	17.2	12.6	2.4	18.7	13.0	2.4	19.4	13.8	2.4	20.3	13.5	2.5	21.6	13.8	2.5	22.8	13.9	2.5
115	13.6	11.0	2.4	14.9	11.1	2.5	15.9	11.7	2.5	17.4	12.1	2.6	18.1	12.8	2.6	18.9	12.5	2.6	20.1	12.9	2.6	21.2	12.9	2.7

TC = Total Capacity

SHC = Sensible Heating Capacity

PI - Power Input

HEATING CAPACITY

MWLD018S6S + MWMD018S6

Outdoor Temp. °F (Dry Bulb)	Indoor Temperature - °F (Dry Bulb)											
	61		64		68		70		72		75	
	TC MBH	PI kW	TC MBH	PI kW	TC MBH	PI kW	TC MBH	PI kW	TC MBH	PI kW	TC MBH	PI kW
-22	11.6	2.3	11.4	2.4	11.2	2.4	11.1	2.4	11.1	2.5	11.0	2.5
-5	20.6	3.2	20.3	3.3	20.0	3.3	19.8	3.4	19.8	3.4	19.5	3.4
-4	21.1	3.3	20.8	3.3	20.5	3.4	20.3	3.4	20.3	3.4	20.0	3.5
0	21.6	3.4	21.3	3.5	21.0	3.5	20.8	3.5	20.8	3.6	20.5	3.6
5	22.3	3.6	22.0	3.6	21.7	3.7	21.4	3.7	21.5	3.7	21.1	3.8
14	24.4	3.6	24.0	3.6	23.6	3.7	23.4	3.7	23.3	3.8	23.0	3.8
23	26.4	3.6	26.0	3.6	25.6	3.7	25.4	3.7	25.2	3.8	24.9	3.8
32	26.8	3.2	26.4	3.3	25.9	3.3	25.7	3.4	25.5	3.4	25.2	3.4
41	26.8	2.8	26.4	2.8	25.9	2.9	25.7	2.9	25.5	2.9	25.2	3.0
47	26.9	2.6	26.4	2.7	26.0	2.7	20.0	1.5	25.6	2.8	25.3	2.8
55	27.1	2.6	26.7	2.6	26.3	2.7	26.1	2.7	25.8	2.7	25.5	2.8
65	27.5	2.6	27.0	2.6	26.6	2.7	26.4	2.7	26.1	2.7	25.8	2.8
75	27.8	2.6	27.4	2.6	26.9	2.7	26.7	2.7	26.5	2.7	26.1	2.7

TC = Total Capacity

PI - Power Input

COOLING CAPACITY

MWLD024S6S + MWMD024S6

Outdoor Temp. °F (Dry Bulb)	Indoor Temperature - °F (Dry Bulb / Wet Bulb)																							
	64 / 53			68 / 57			72 / 61			77 / 64			80 / 67			82 / 70			86 / 72			90 / 75		
	TC MBH	SHC MBH	PI kW	TC MBH	SHC MBH	PI kW	TC MBH	SHC MBH	PI kW	TC MBH	SHC MBH	PI kW	TC MBH	SHC MBH	PI kW	TC MBH	SHC MBH	PI kW	TC MBH	SHC MBH	PI kW	TC MBH	SHC MBH	PI kW
-0.4	20.1	16.1	1.4	22.0	16.3	1.4	23.5	17.1	1.4	25.6	17.8	1.5	26.4	18.9	1.6	27.8	18.4	1.5	29.4	18.9	1.6	31.2	19.0	1.6
32	20.5	16.4	1.3	22.4	16.6	1.3	23.9	17.4	1.4	26.1	18.1	1.4	26.9	19.2	1.5	28.2	18.7	1.5	30.0	19.2	1.5	31.8	19.3	1.5
50	20.5	16.0	1.3	22.2	16.2	1.3	23.7	17.0	1.4	25.8	17.5	1.4	26.8	18.6	1.5	27.9	18.1	1.4	29.5	18.5	1.5	31.2	18.5	1.5
68	20.2	15.7	1.3	21.9	15.8	1.4	23.4	16.5	1.4	25.4	17.0	1.5	26.4	18.1	1.6	27.4	17.5	1.5	28.9	17.9	1.6	30.5	17.9	1.6
85	20.8	16.0	2.3	22.7	16.1	2.3	24.3	16.9	2.4	26.4	17.5	2.4	27.5	18.6	2.5	28.6	18.1	2.5	30.3	18.5	2.5	32.1	18.5	2.6
95	21.3	16.2	2.9	23.3	16.4	3.0	24.9	17.2	3.0	27.2	17.8	3.1	22.0	17.6	1.7	29.5	18.5	3.1	31.3	19.0	3.2	33.2	19.0	3.2
104	18.4	14.1	2.8	20.1	14.2	2.8	21.6	14.9	2.9	23.5	15.4	2.9	24.4	16.4	3.0	25.5	16.0	3.0	27.1	16.4	3.0	28.7	16.4	3.1
110	16.5	12.6	2.7	18.1	12.7	2.8	19.3	13.4	2.8	21.1	13.9	2.9	21.9	14.7	2.9	22.9	14.3	2.9	24.3	14.7	2.9	25.8	14.8	3.0
115	15.0	11.5	2.7	16.4	11.6	2.7	17.6	12.1	2.8	19.2	12.6	2.8	19.9	13.3	2.8	20.8	13.0	2.8	22.1	13.4	2.9	23.4	13.4	2.9

TC = Total Capacity

SHC = Sensible Heating Capacity

PI - Power Input

HEATING CAPACITY

MWLD024S6S + MWMD024S6

Outdoor Temp. °F (Dry Bulb)	Indoor Temperature - °F (Dry Bulb)											
	61		64		68		70		72		75	
	TC MBH	PI kW	TC MBH	PI kW	TC MBH	PI kW	TC MBH	PI kW	TC MBH	PI kW	TC MBH	PI kW
-22	12.0	2.3	11.9	2.4	11.7	2.4	11.6	2.4	11.6	2.4	11.4	2.5
-5	23.7	4.0	23.3	4.1	23.0	4.1	22.7	4.2	22.8	4.2	22.4	4.2
-4	24.3	4.1	24.0	4.2	23.7	4.2	23.4	4.3	23.4	4.3	23.1	4.4
0	24.8	4.0	24.5	4.1	24.1	4.1	23.9	4.1	23.9	4.2	23.5	4.2
5	25.4	3.9	25.1	3.9	24.7	4.0	24.4	4.0	24.5	4.0	24.1	4.1
14	26.7	3.6	26.3	3.7	25.9	3.7	25.7	3.7	25.6	3.8	25.2	3.8
23	28.0	3.3	27.5	3.4	27.1	3.5	26.9	3.5	26.6	3.5	26.3	3.6
32	29.5	3.3	29.1	3.4	28.6	3.4	28.4	3.4	28.1	3.5	27.8	3.5
41	28.2	2.7	27.8	2.7	27.3	2.8	27.1	2.8	26.8	2.8	26.5	2.9
47	28.2	2.4	27.8	2.5	27.3	2.5	25.0	2.0	26.9	2.6	26.6	2.6
55	30.1	2.5	29.7	2.5	29.2	2.6	29.0	2.6	28.7	2.6	28.4	2.7
65	32.5	2.6	32.0	2.6	31.5	2.7	31.3	2.7	31.0	2.7	30.6	2.7
75	35.0	2.7	34.4	2.7	33.9	2.7	33.6	2.8	33.3	2.8	32.9	2.8

TC = Total Capacity

PI - Power Input

MWLD009S6S | MWLD012S6S

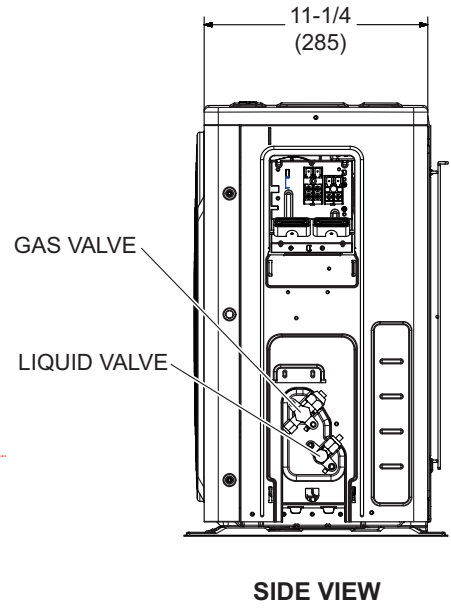
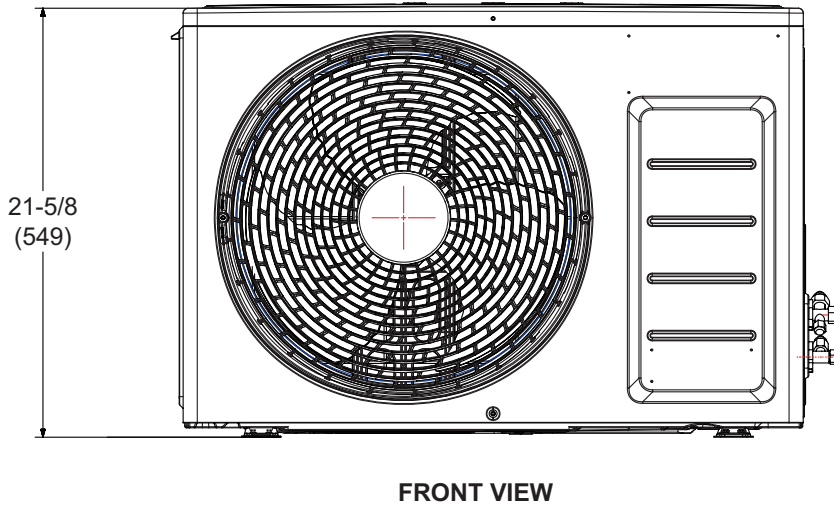
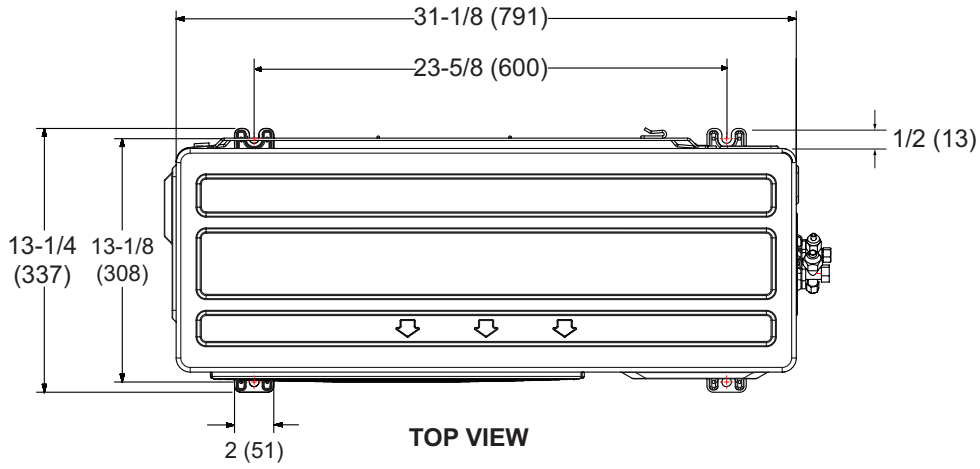

MWLD015S6S

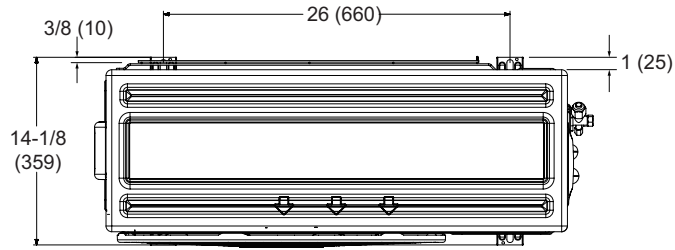

TOP VIEW

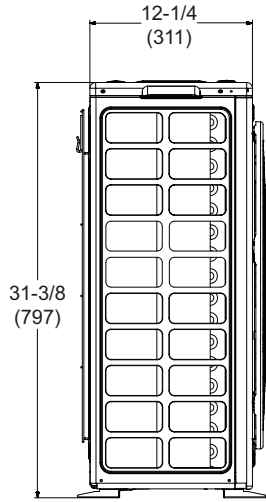

SIDE VIEW

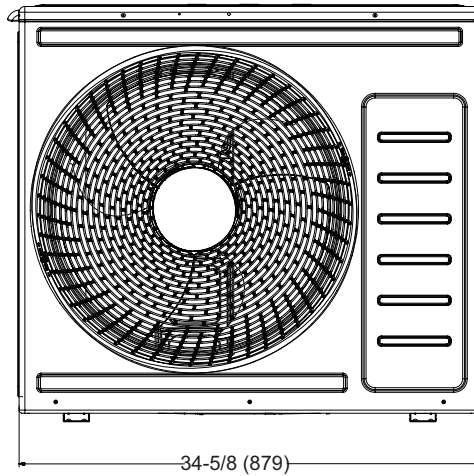

FRONT VIEW

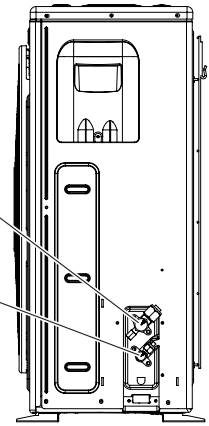

SIDE VIEW

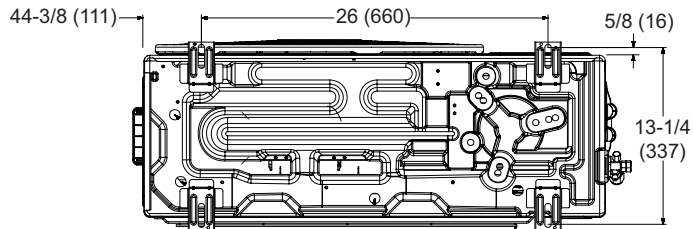

BOTTOM VIEW

MWLD018S6S | MWLD024S6S

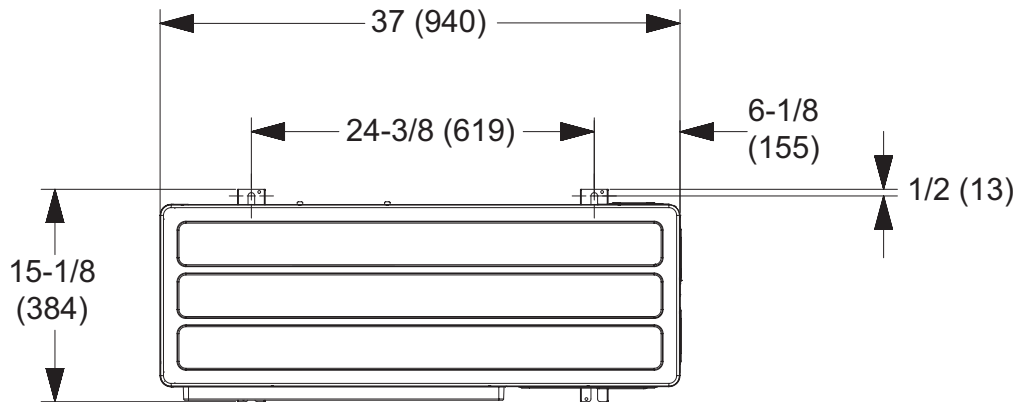

TOP VIEW

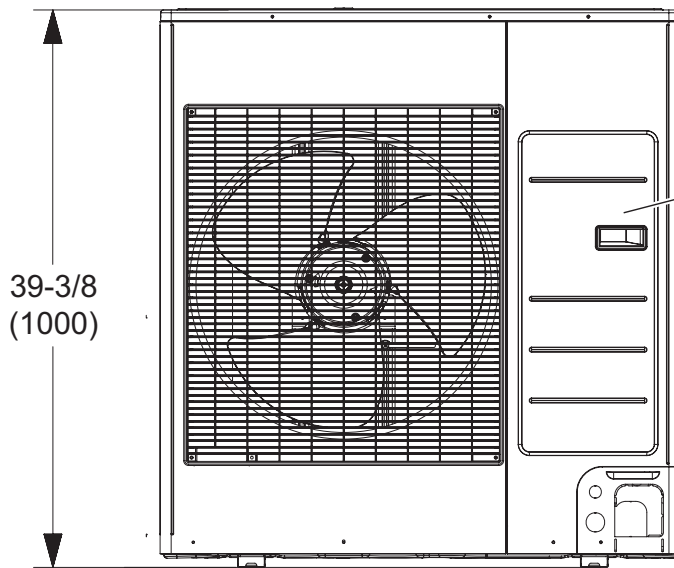

FRONT VIEW

LIQUID AND GAS VALVES (Under Cover)

LIQUID PIPE INLET

GAS PIPE INLET

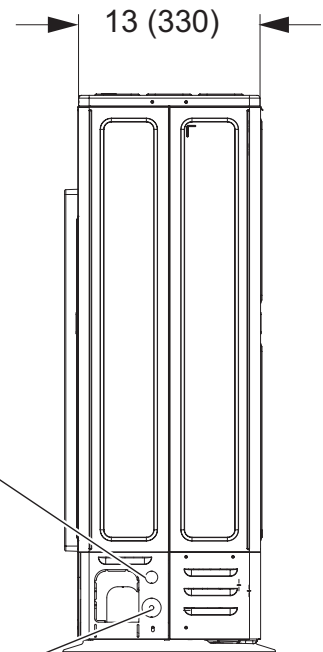

SIDE VIEW

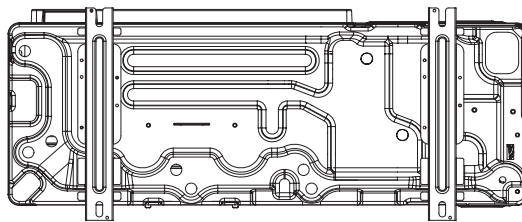

BOTTOM VIEW (51)

MWLD009S6 | MWLD012S6, MWLD015S6

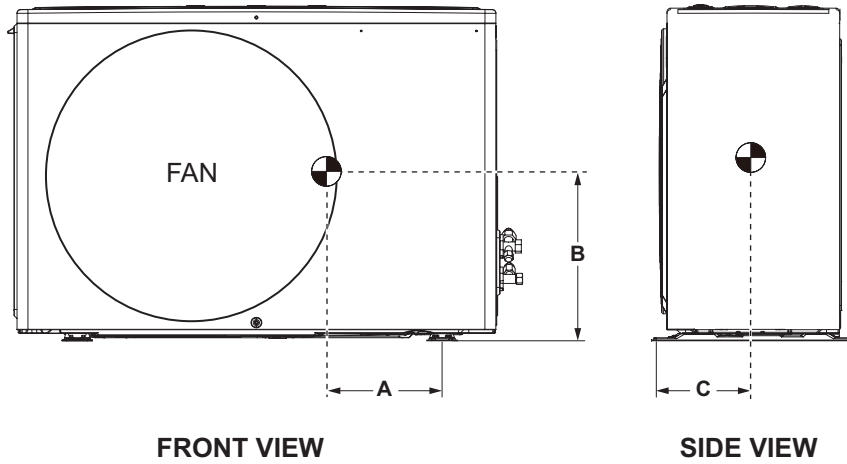

MWLD018S6, MWLD024S6

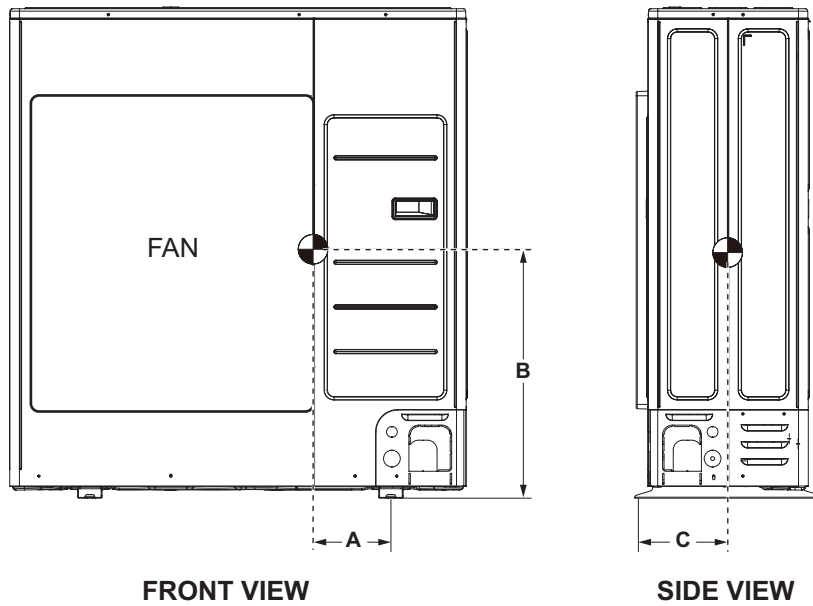

Dimensions	009		012		015		018		024	
	in.	mm	in.	mm	in.	mm	in.	mm	in.	mm
A	7-1/2	191	7-1/2	191	9-7/8	250	8-1/8	207	8-1/8	207
B	11	279	11	279	13-3/4	350	17-1/2	444	17-1/2	444
C	6-1/8	155	6-1/8	155	6-3/8	162	7	178	7	178

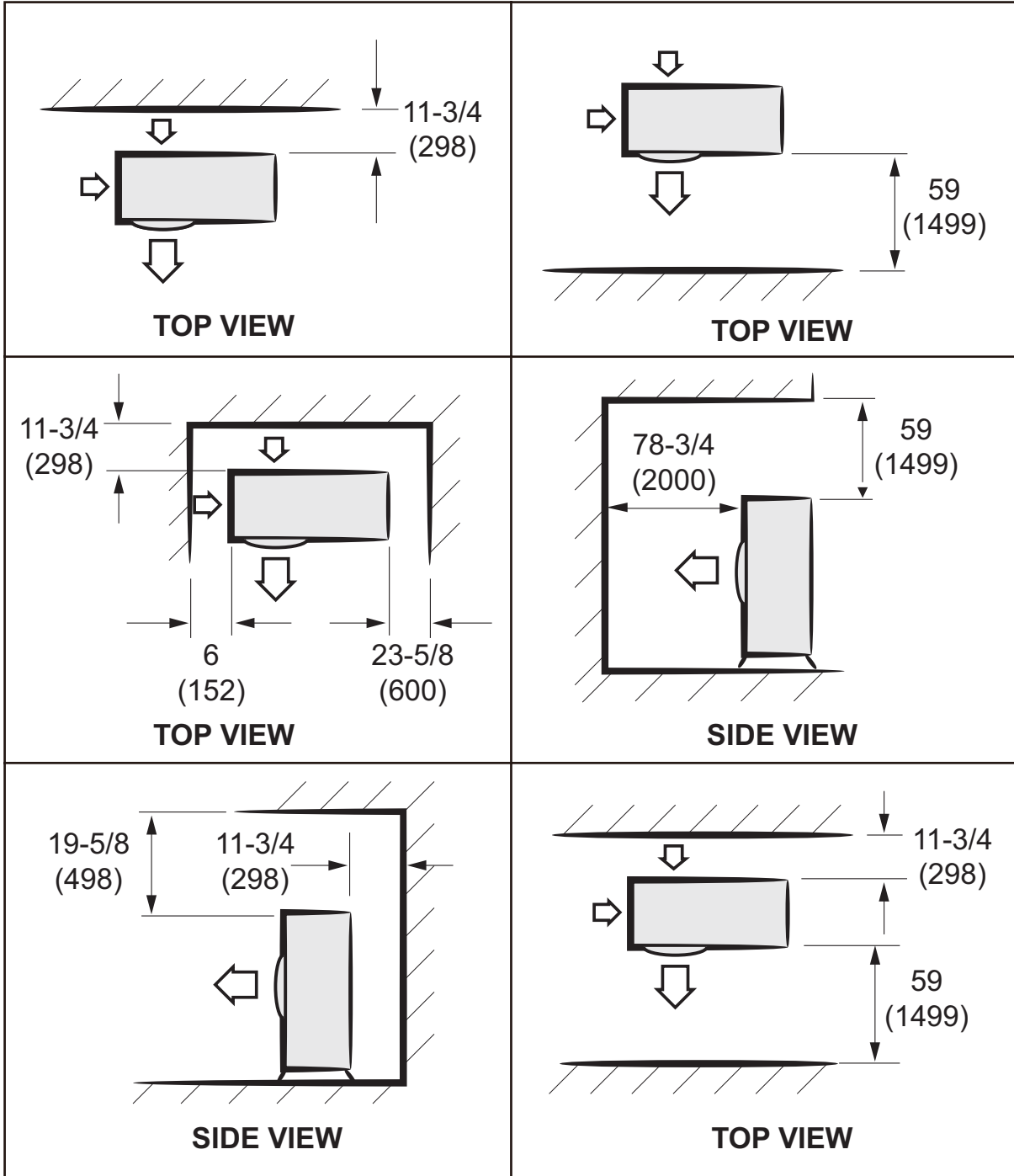

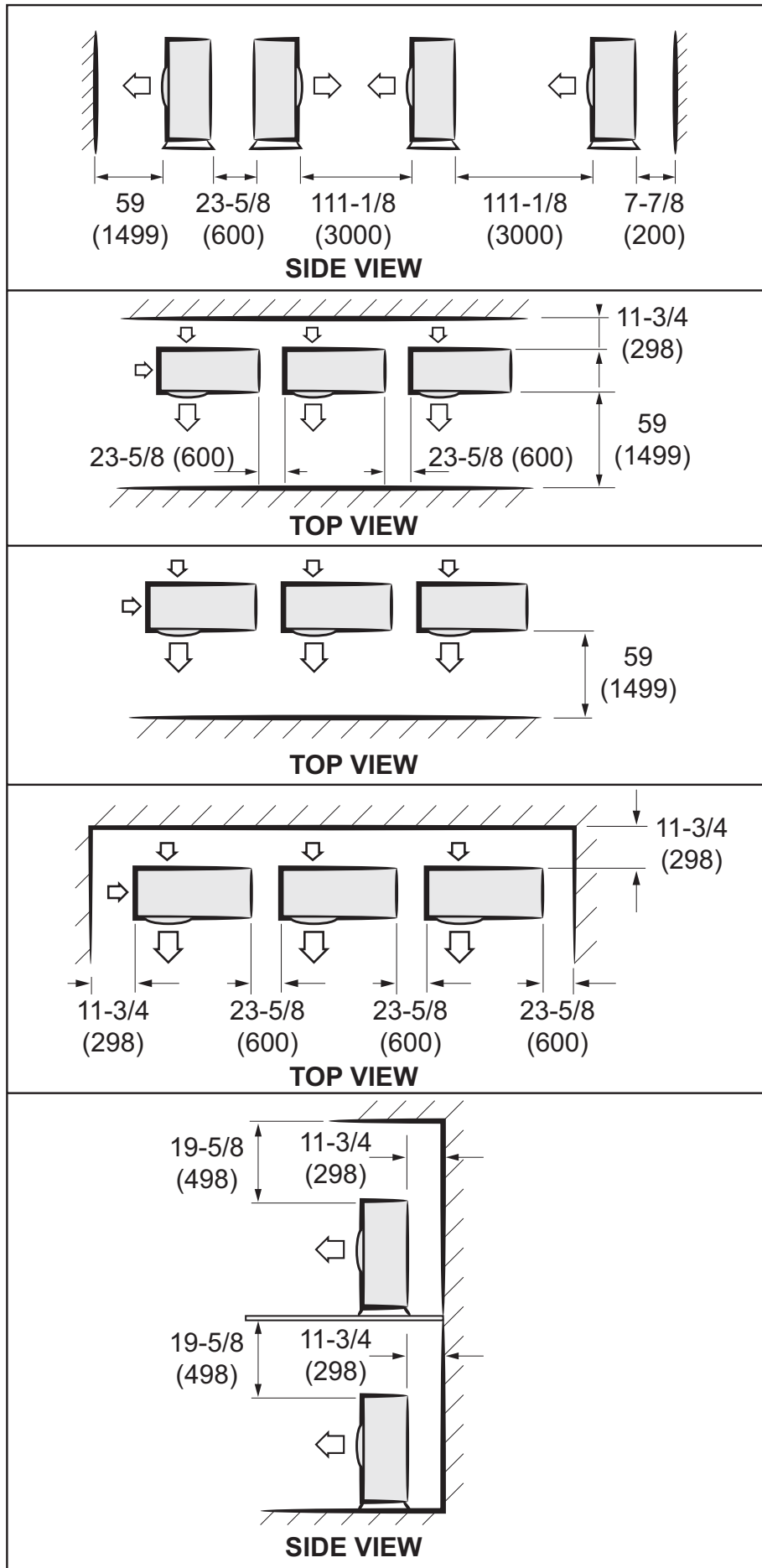

Sound Pressure level

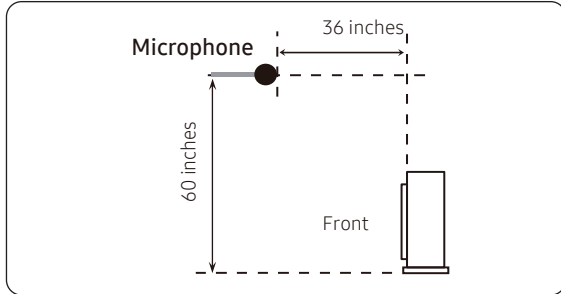

Unit: dBA

Model	Cooling
MWLD009S6S-1P	45
MWLD012S6S-1P	46
MWLD015S6S-1P	48
MWLD018S6S-1P	51
MWLD024S6S-1P	54

• NC Curve

1) MWLD009S6S-1P

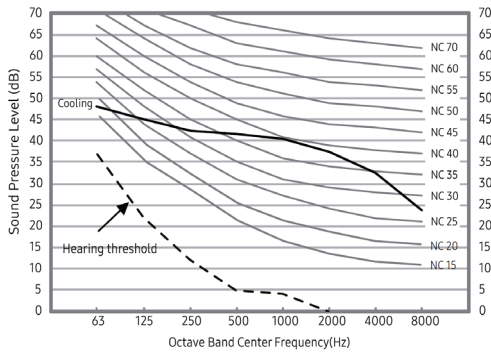

2) MWLD012S6S-1P

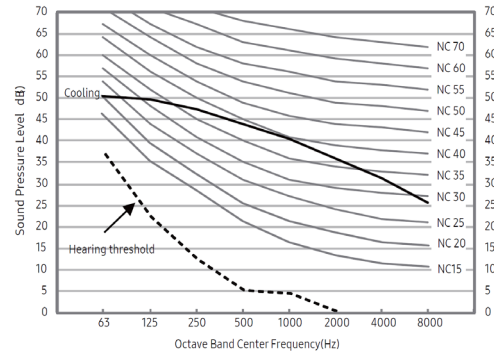

3) MWLD015S6S-1P

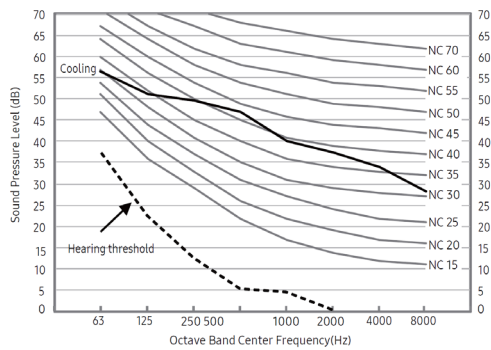

4) MWLD018S6S-1P

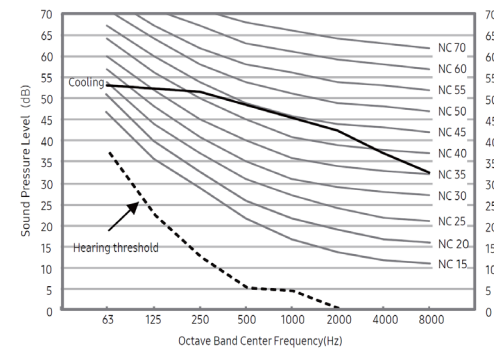

5) MWLD024S6S-1P

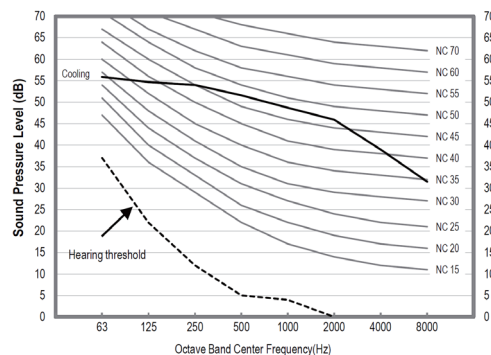

NOTE

- Specifications may be subject to change without prior notice.
- Sound pressure Level
 - Sound pressure level is obtained in an anechoic room.
 - Sound pressure level is a relative value, depending on the distance and acoustic environment.
 - Sound pressure level may differ depending on operation condition.
 - dBA = A weighted sound pressure level
 - Reference acoustic pressure 0 dB = 20µPa

OPERATION RANGE

Cooling

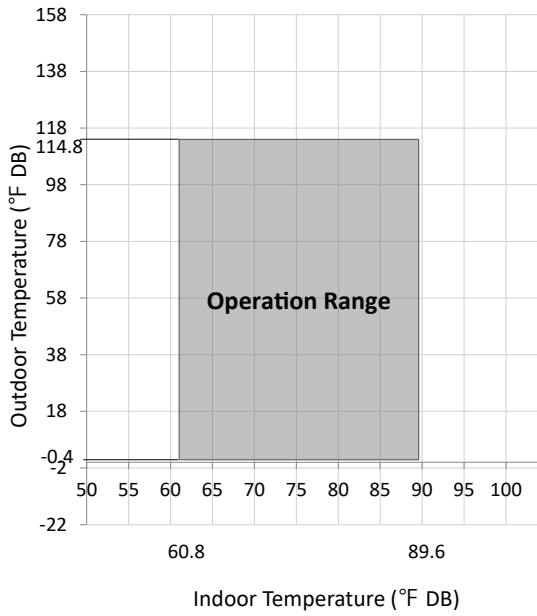

Heating

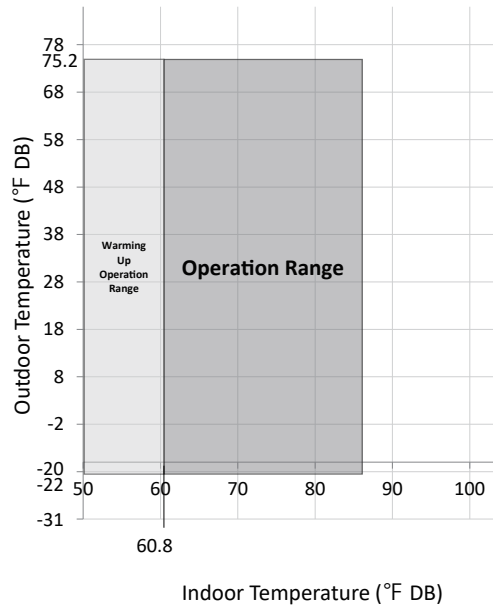

CAPACITY CORRECTION

9/12KBtu/h

Cooling

		Pipe Length (ft)				
		16	33	41	49	66
Level Difference (ft)	49	-	-	-	0.92	0.90
	33	-	0.95	0.94	0.93	0.91
	23	-	0.96	0.95	0.94	0.92
	16	0.99	0.97	0.96	0.95	0.93
	0	1.00	0.98	0.97	0.96	0.94
	-16	0.99	0.97	0.96	0.95	0.93
	-23	-	0.96	0.95	0.94	0.92
	-33	-	0.95	0.94	0.93	0.91
	-49	-	-	-	0.92	0.90

Heating

		Pipe Length (ft)				
		16	33	41	49	66
Level Difference (ft)	49	-	-	-	0.92	0.90
	33	-	0.95	0.94	0.93	0.91
	26	-	0.96	0.95	0.94	0.92
	16	0.99	0.97	0.96	0.95	0.93
	0	1.00	0.98	0.97	0.96	0.94
	-16	0.99	0.97	0.96	0.95	0.93
	-26	-	0.96	0.95	0.94	0.92
	-33	-	0.95	0.94	0.93	0.91
	-49	-	-	-	0.92	0.90

CAPACITY CORRECTION

15/18/24KBtu/h

Cooling

		Pipe Length (ft)							
		16	33	41	49	66	82	98	
	Level Difference (ft)	66	-	-	-	-	-	0.87	0.85
		49	-	-	-	0.92	0.90	0.88	0.86
		33	-	0.95	0.94	0.93	0.91	0.89	0.87
		23	-	0.96	0.95	0.94	0.92	0.9	0.88
		16	0.99	0.97	0.96	0.95	0.93	0.91	0.89
		0	1.00	0.98	0.97	0.96	0.94	0.92	0.90
		-16	0.99	0.97	0.96	0.95	0.93	0.91	0.89
		-23	-	0.96	0.95	0.94	0.92	0.9	0.88
		-33	-	0.95	0.94	0.93	0.91	0.89	0.87
		-49	-	-	-	0.92	0.90	0.88	0.86
		-66	-	-	-	-	-	0.87	0.85

Heating

		Pipe Length (ft)							
		16	33	41	49	66	82	98	
	Level Difference (ft)	66	-	-	-	-	-	0.87	0.85
		49	-	-	-	0.92	0.90	0.88	0.86
		33	-	0.95	0.94	0.93	0.91	0.89	0.87
		23	-	0.96	0.95	0.94	0.92	0.9	0.88
		16	0.99	0.97	0.96	0.95	0.93	0.91	0.89
		0	1.00	0.98	0.97	0.96	0.94	0.92	0.90
		-16	0.99	0.97	0.96	0.95	0.93	0.91	0.89
		-23	-	0.96	0.95	0.94	0.92	0.90	0.88
		-33	-	0.95	0.94	0.93	0.91	0.89	0.87
		-49	-	-	-	0.92	0.90	0.88	0.86
		-66	-	-	-	-	-	0.87	0.85

REVISIONS

Sections	Description of Change
AHRI Ratings	Updated.



Visit us at www.Lennox.com

For the latest technical information, www.LennoxPros.com

Contact us at 1-800-9-LENNOX

NOTE - Due to Lennox' ongoing commitment to quality, Specifications, Ratings and Dimensions subject to change without notice and without incurring liability. Improper installation, adjustment, alteration, service or maintenance can cause property damage or personal injury. Installation and service must be performed by a qualified installer and servicing agency.

©2026 Lennox Industries, Inc.