



Variable Capacity - Precise Comfort® Technology - R-410A - 60 Hz

EL22XPV

ELITE® Series

**RESIDENTIAL
PRODUCT SPECIFICATIONS**

Bulletin No. 210988
August 2023
Supersedes June 2023

**ELITE®
SERIES**



S40 Smart Wi-Fi
Communicating Thermostat
(not furnished - ordered separately)



SEER2 up to 22.0 / SEER up to 23.0
HSPF2 up to 9.0 / HSPF up to 10.35
2 to 5 Tons

Cooling Capacity - 22,800 to 55,500 Btuh
Heating Capacity - 22,200 to 58,000 Btuh

MODEL NUMBER IDENTIFICATION

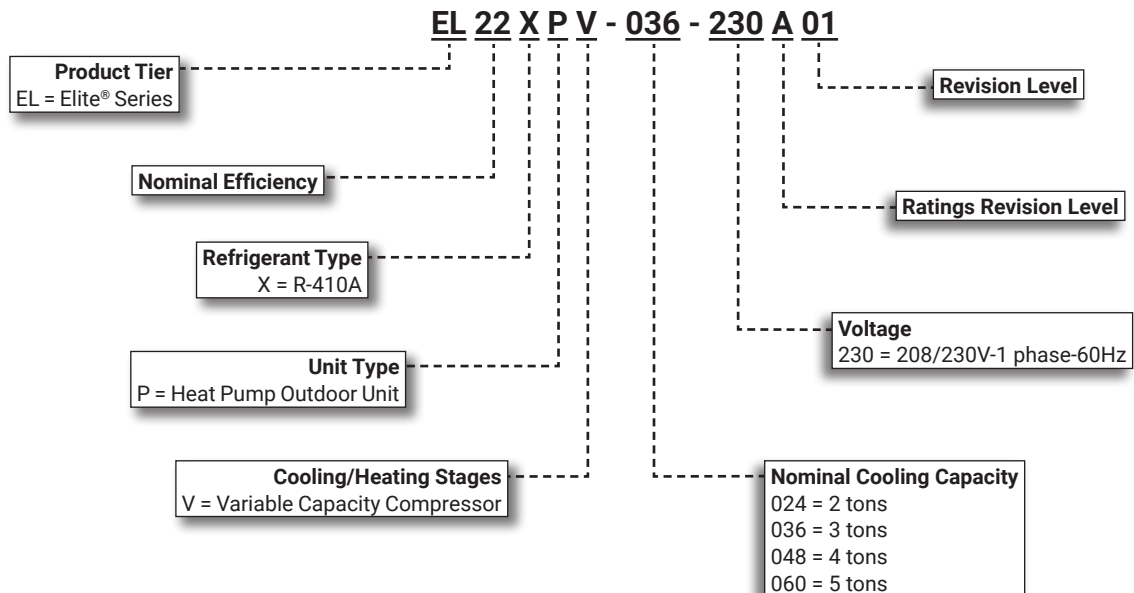

FEATURE HIGHLIGHTS

1. Outdoor Coil Fan
2. Quantum™ Coil
3. High Capacity Liquid Line Drier
4. High Pressure Switch
5. Four-Way Reversing Valve
6. Variable Speed Compressor
7. DC Inverter Control
8. Lennox® Communicating Control
9. Heavy Gauge Steel Cabinet
10. SmartHinge™ Louvered Coil Protection
11. Refrigerant Line Connections and Access

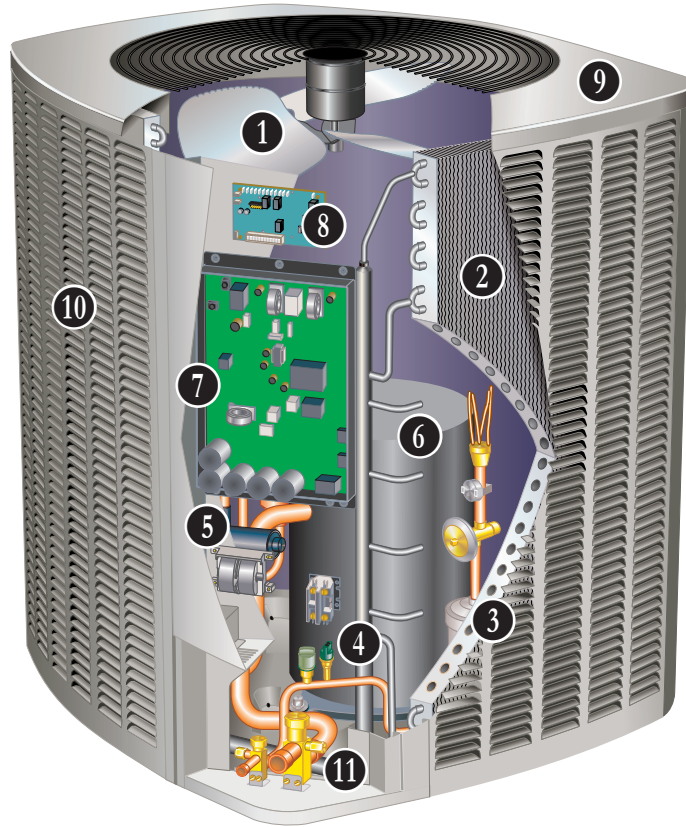

CONTENTS

Approvals And Warranty	3
Dimensions - Unit	11
Electrical Data	9
Features	3
Field Wiring	10
Installation Clearances	10
Optional Accessories - Order Separately	9
Sound Data	10
Specifications	9
TXV Substitution	12
TXV Usage.	12

APPROVALS AND WARRANTY

APPROVALS

- AHRI Standard 210/240-2023 certified
- AHRI Certified system match-ups and expanded ratings, visit www.LennoxPros.com

NOTE - AHRI certified ratings are based on the following control conditions:

A Lennox® Communicating thermostat matched with a “communicating” indoor unit.

Any conventional non-communicating thermostat matched with a conventional “non-communicating” indoor unit.

- ENERGY STAR® Certified (certain units)
- Sound rated to AHRI Standard 270-2008 test conditions
- Tested in Lennox’ Research Laboratory environmental test room
- Rated According to U.S. Department of Energy (DOE) test procedures
- Region specific models meet the minimum efficiency requirements for U.S. DOE Federal Regional Standards in that area
- Unit and components ETL, NEC and CEC bonded for grounding to meet safety standards for servicing
- ETL certified (U.S. and Canada)
- ISO 9001 Registered Manufacturing Quality System

WARRANTY

- Compressor:
 - Limited ten years in residential installations
 - Limited five years in non-residential installations
- **All other covered components:**
 - Limited five years in residential installations
 - Limited one year in non-residential installations

NOTE - Refer to Lennox® Basic Limited Warranty at www.Lennox.com for additional details.

FEATURES

APPLICATIONS

- 2 through 5 ton
- Sound levels as low as 61 dBA
- Single-phase power supply
- Applicable to indoor air handlers or gas furnaces with indoor add-on coils
- Shipped completely factory assembled, piped and wired

NOTE - When heat pumps are used with gas furnaces, a dual-fuel compatible thermostat or zone control system with dual-fuel capabilities must be used (order separately).

NOTE - Installer must set outdoor unit, connect refrigerant lines and make electrical connections to complete job.

REFRIGERATION SYSTEM

R-410A Refrigerant

- Non-chlorine, ozone friendly
- Unit is factory pre-charged

NOTE - Total system refrigerant charge is dependent on outdoor unit size, indoor unit size and refrigerant line length.

NOTE - Refer to the unit-mounted charging sticker to determine correct amount of charge required.

- Vertical air discharge
- Totally enclosed fan motor
- Ball bearings
- Inherently protected
- PVC (polyvinyl chloride) coated steel fan guard

2 Quantum™ Coil

- Lennox designed and fabricated coil
- Enhanced aluminum alloy tube/enhanced fin coil
- Superior corrosion resistance
- Ripple-edged aluminum fins
- Aluminum tube construction
- Lanced fins for maximum fin surface exposure
- Fin collars grip tubing for maximum contact area
- Flared shoulder tubing connections
- Factory tested under high pressure
- Entire coil is accessible for cleaning

Expansion Valve - Outdoor Unit

- Designed and sized specifically for use in heat pump system
- Sensing bulb is located on the line between reversing valve and the coil
- Senses suction temperature during the heating cycle
- Factory installed and piped

1 Outdoor Coil Fan

- Direct drive fan
- ECM motor

FEATURES

REFRIGERATION SYSTEM (continued)

Discharge Temperature Switch

- Shuts off unit if operating conditions cause the compressor discharge line temperature to rise above setpoint
- Protects compressor from excessive pressure / temperature
- Automatic reset when temperature drops below setpoint

3 High Pressure Transducer

- Protects the system from high pressure conditions
- Automatic reset

Low Pressure Transducer

- Shuts off unit if suction pressure falls below setting
- Provides loss of charge and freeze-up protection
- Automatic reset

4 High Capacity Liquid Line Drier

- Factory installed in the liquid line
- Drier traps moisture or dirt
- 100% molecular-sieve, bead type, bi-flow drier

5 Four-Way Reversing Valve

- Rapid changeover of refrigerant flow direction from cooling to heating and vice versa
- Operates on pressure differential between outdoor unit and indoor coil
- Factory installed

Optional Accessories

Expansion Valve Kits

- Field installed on certain indoor units
- See TXV Usage table
- Chatleff-style fitting

Freezestat

- Senses suction line temperature
- Cycles compressor off when suction line temperature falls below it's setpoint
- Opens at 29°F and closes at 58°F
- Installs on or near the discharge line of the evaporator or on the suction line

Refrigerant Line Kits

- Refrigerant lines are shipped refrigeration clean
- Lines are cleaned, dried, pressurized and sealed at factory
- Suction line fully insulated
- Lines are stubbed at both ends

NOTE - The EL22XPV is a variable capacity heat pump utilizing variable speed compressor technology. With the variable speed compressor and variable pumping capacity, additional consideration must be given to refrigerant piping sizing and application. Please refer to the Installation Instructions or Service Literature for Line Set Requirements and Refrigerant Piping Guidelines.

FEATURES

PRECISE COMFORT® TECHNOLOGY

The Variable Capacity Rotary Compressor and DC Inverter Control is an integrated system that operates together to reduce overall energy usage when compared to conventional heat pumps.

6 Variable Capacity Compressor

- Rotary compressor - 024 and 036 models
- Scroll compressor - 048 and 060 model
- High volumetric efficiency
- Uniform suction flow
- Constant discharge flow
- Quiet operation
- Low gas pulses during compression reduces operational sound levels
- Compressor motor is internally protected from excessive current and temperature
- Compressor is installed in the unit on resilient rubber mounts for vibration free operation

Rotary Compressor Operation (024 and 036 Models)

- Rotary compressor has a cylindrical chamber
- A roller is mounted to the motor shaft and is offset to rotate in the center of the chamber
- Two spring-loaded vanes sweep the sides of the chamber as the roller rotates
- Roller touches the chamber at a point between the intake and the discharge ports as the roller rotates
- While rotating, the roller draws vapor into the chamber through the intake port
- Vapor is trapped in the space between the chamber wall, the vane, and the point of contact between the roller and the chamber
- As the next vane passes the contact point vapor is compressed
- The space becomes smaller compressing the vapor as the roller rotates
- Vapor is discharged through the discharge port

Scroll Compressor Operation (048 and 060 Model)

- Two involute spiral scrolls matched together generate a series of crescent shaped gas pockets between them
- During compression, one scroll remains stationary while the other scroll orbits around it
- Gas is drawn into the outer pocket, the pocket is sealed as the scroll rotates
- As the spiral movement continues, gas pockets are pushed to the center of the scrolls
- Volume between the pockets is simultaneously reduced
- When the pocket reaches the center, gas is now at high pressure and is forced out of a port located in the center of the fixed scrolls
- During compression, several pockets are compressed simultaneously resulting in a smooth continuous compression cycle
- Continuous flank contact, maintained by centrifugal force, minimizes gas leakage and maximizes efficiency

- Compressor is tolerant to the effects of slugging and contaminants

Compressor Crankcase Heater

- Protects against refrigerant migration that can occur during low ambient operation
- Factory Installed

Compressor Sound Dampening System

- Polyethylene compressor
- 2 inch thick batt fiberglass insulation
- All open edges sealed with one-inch wide hook and loop fastening tape

CONTROLS

7 DC Inverter Control

- Converts AC line voltage into filtered variable DC voltage
- Provides continuous compressor operation, while adjusting the capacity according to indoor temperature
- Adjusts compressor output in increments as small as 1%
- The accurate sensing of the cooling or heating load prevents frequent changes in capacity and ensures efficient, economical operation
- Power Factor Correction (PFC) circuit monitors the DC bus for high, low and abnormal voltage conditions to protect the compressor
- Two LEDs (red and green) indicate inverter operating status and aid in troubleshooting
- Noise filter reduces unwanted electromagnetic interference (EMI)
- Integrated on the Lennox® Communicating Control for 024 and 036 models,
- Separate external inverter control for 048 and 060 models
- The inverter reactor (mounted separately) adds inductance to the line between the inverter and the compressor to limit current rise and protect the compressor



FEATURES

CONTROLS (continued)

8 Lennox® Communicating Control

- Advanced control communicates information about various operating parameters in the heat pump to the Lennox® Communicating Thermostats to constantly maintain the highest level of comfort, performance and efficiency available
- Connections for connecting a conventional heating/cooling thermostat are also provided on the control
- **Auto Configuration** - On start-up the control automatically sends a description of the unit to the Lennox® Communicating Thermostat to automatically configure the features available
- Control also features:
 - **Seven-Segment Display** - Shows information about outdoor unit type and capacity and also displays alerts for common fault conditions (electrical and mechanical)
 - **Low Voltage Protection** - Prevents compressor operation when voltage is not within the specified range
 - High and low pressure switch monitoring with provisions for lockout
 - Five-Strike lockout protection protects compressor
 - Liquid line temperature and sensor monitoring
 - EEPROM storage of all local configurations
 - Non-volatile memory storage of 100 alarm codes with display of last 10 codes for troubleshooting
 - Built-in low-ambient control

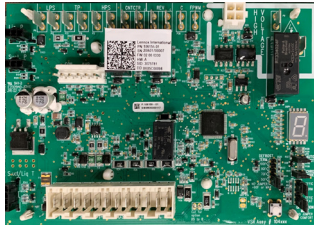

NOTE - Two RAST connectors for a conventional heating/cooling thermostat are also provided for connecting to the control. A two-stage or single-stage thermostat can be used.

Low Ambient Operation

- Cooling Mode - The heat pump can operate down to 0°F outdoor air temperature in the cooling mode

NOTE - A freeze-stat is recommended for extra protection during low ambient cooling operation.

Heating Mode (Low Temperature Protection)

- Outdoor unit will not operate in the heating mode when the outdoor temperature is at or below -4°F
- If the unit is operating and the outdoor temperature drops below -4°F, the unit will continue to operate until the room thermostat is satisfied or the outdoor temperature drops to -15°F

Climate IQ™ Technology

- Optimizes dehumidification settings for specific climates to improve home comfort during cooling or heating operation
- Monitors regional weather conditions and automatically removes excess humidity when necessary

Lennox® Communicating Thermostat Settings: Cooling Mode

- Three climate settings are available:
 - **Dry** - The system supplies higher indoor airflow at all compressor capacities, increasing efficiency by operating at a higher sensible to total ratio
 - **Moderate** - The system supplies indoor airflow that balances efficiency and comfort
 - **Humid** - The system supplies lower indoor airflow at all compressor capacities, improving humidity removal by operating at a lower sensible to total ratio

Heating Mode

- Two climate settings are available:
 - **Normal** - Heats the home with the highest efficiency
 - **Comfort** - System reduces indoor airflow, increasing supply air temperature
- Climate IQ (Auto) - Dry, Normal, Basic and Humid modes are automatically set based on the difference between the measured relative humidity and the relative humidity setting
- All modes are selected on the Lennox® Communicating Thermostat

Outdoor Air Temperature Sensor

- Used with Lennox® Communicating Thermostats
- Sensor allows thermostat to display outdoor temperature
- Sensor is auto-detected when connected to thermostat

Optional Accessories

Indoor Blower Off Delay Relay

- Delays the indoor blower-off time during the cooling cycle

FEATURES

CONTROLS (continued)

NOTE - The EL22XPV Heat Pump can be used with a Lennox® Communicating Thermostat matched with a “communicating” indoor unit, or a conventional non-communicating thermostat matched with a “non-communicating” indoor unit.

Thermostat	Model No.	Indoor Unit Type
Communicating	S40	Communicating
Non-Communicating	E30, M30, CS7500	Non-Communicating
	Conventional thermostat	

Optional Accessories

S40 Smart Wi-Fi Thermostat (part of the Lennox® Residential Communicating Control System)

- Recognizes and connects to all Lennox® Communicating products to automatically configure and control the heating/cooling system (based on user-specified settings) for the highest level of comfort, performance and efficiency
- Recognizes model and serial number information for Lennox® Communicating products to simplify system setup
- Lennox Smart Room Sensors, Lennox Wireless Extenders and Lennox Smart Air Quality Monitor can be added to the system
- Smart home automation compatible with Amazon Alexa®, Google Assistant, Control4® and Building36®
- Sends service alerts and reminders
- Lennox Smart Thermostat App features Wi-Fi remote temperature monitoring and adjustment through a home wireless network apps for smartphones or tablets
- Lennox Smart Technician App allows installer to manage systems in the home
- Service Dashboard features online real-time monitoring and advanced diagnostics of installed Lennox® Communicating systems
- Simple easy-to-use touchscreen allows complete system configuration
- Scheduled maintenance alerts, system warnings and troubleshooting are also displayed on thermostat screen
- Easy to read 7 inch high definition color display (measured diagonally)
- Conventional outdoor units (not Lennox® Communicating) can easily be added and controlled by the S40 Thermostat
- Installer setup screens allow quick and simple system configuration without a manual, Installer can also run tests on complete system or individual components for easy maintenance and troubleshooting
- Serial communications bus (RSBus), with less wiring than a conventional heating/cooling system, allows system communication
- Uses standard 4-wire unshielded thermostat wiring
- High Definition Color Display with Subbase and wallplate furnished for easy installation



NOTE - See the Lennox® S40 Thermostat Product Specifications bulletin in the Controls section for more information.

E30 Smart Wi-Fi Thermostat

- Wi-Fi enabled, electronic 7-day, universal, multi-stage, programmable, touchscreen thermostat
- 3 Heat/2 Cool
- Auto-changeover
- Controls dehumidification during cooling mode and humidification during heating mode
- Offers enhanced capabilities including humidification / dehumidification / dewpoint measurement and control, Humiditrol® control, and equipment maintenance reminders
- Easy to read 7 in. color touchscreen (measured diagonally)
- LCD display with backlight shows the current and set temperature, time, inside relative humidity, system status (operating mode and schedules) and outside temperature (optional outdoor sensor required)
- Smooth Setback Recovery starts system early to achieve setpoint at start of program period
- Compressor short-cycle protection (5 minutes)
- Up to four separate schedules are available plus Schedule IQ™
- One-Touch Away Mode - A quick and easy way to set the cooling and heating setpoints while away
- Smart Away™ - Uses geo-fencing technology to determine when the homeowner is within a predetermined distance from the home to operate the system when leaving, away and arriving
- Wi-Fi remote monitoring and adjustment through a home wireless network for desktop PCs, laptops and apps for smartphones or tablets
- Smart home automation compatible with Apple HomeKit™, Amazon Alexa®, Google Assistant and IFTTT
- Service Dashboard features online real-time monitoring of installed Lennox® thermostats
- High Definition Color Display with Subbase, Smart Hub Controller, wallplate (for retrofit installations) furnished for easy installation



NOTE - See the Lennox® E30 Smart Wi-Fi Thermostat Product Specifications bulletin for more information.

Thermostat

- Thermostat is not furnished with unit
- See Lennox Price Book for selection

FEATURES

CABINET

- 9 • Heavy-gauge steel construction
- Pre-painted cabinet finish
- Louvered heavy gauge steel panels surround unit on all four sides
- Control box is conveniently located with all controls factory wired
- Corner patch plate allows access to compressor components
- Drainage holes are provided in base section for moisture removal
- High density polyethylene unit support feet raise the unit off of the mounting surface, away from damaging moisture

PermaGuard™ Unit Base

- Durable zinc-coated base section resists rust and corrosion

10 **SmartHinge™ Louvered Coil Protection**

- Steel louvered panels provides complete coil protection
- Panels are hinged to allow easy cleaning and servicing of coils
- Panels may be completely removed
- Interlocking tabs and slots assure tight fit on cabinet



11 **Refrigerant Line Connections, Electrical Inlets and Service Valves**

- Sweat connection vapor and liquid lines
- Located on corner of unit cabinet
- Vapor valve can be fully shut off, while liquid valve may be front seated to manage refrigerant charge while servicing system
- Refrigerant line connections and field wiring inlets are located in one central area of the cabinet
- See dimension drawing

Optional Accessories

Snow Guards

- For use in locations where the possibility of heavy snow or freezing rain accumulation may occur
- Heavy gauge powder coated steel guard deflects snow and ice away from the outdoor fan and prevents build-up on the fan guard

SPECIFICATIONS

General Data		Model No.	EL22XPV-024	EL22XPV-036	EL22XPV-048	EL22XPV-060
		Nominal Tonnage	2	3	4	5
Connections (sweat)	Liquid line (o.d.) - in.		3/8	3/8	3/8	3/8
	Vapor line (o.d.) - in.		3/4	7/8	7/8	1-1/8
Refrigerant		¹ R-410A charge furnished	12 lbs. 5 oz.	12 lbs. 7 oz.	13 lbs. 7 oz.	13 lbs. 2 oz.
Outdoor Coil	Net face area - sq. ft.	Outer coil	21.00	21.00	27.22	27.22
		Inner coil	20.27	20.27	26.36	26.36
	Tube diameter - in.		5/16	5/16	5/16	5/16
	No. of rows		2	2	2	2
	Fins per inch		22	22	22	22
Outdoor Fan	Diameter - in.		26	26	26	26
	No. of blades		3	3	3	3
	Motor hp		1/3	1/3	1/3	1/3
	Cfm		2580	3650	3860	4550
	Rpm		720	765	805	970
	Watts		69	155	169	263
Shipping Data - lbs. 1 package			250	250	358	360

ELECTRICAL DATA

Line voltage data - 60 Hz	208/230V-1ph	208/230V-1ph	208/230V-1ph	208/230V-1ph	
² Maximum Overcurrent Protection (MOCP) amps	20	30	40	50	
³ Minimum Circuit Ampacity (MCA)	13.4	19.9	24.6	33.5	
Compressor	Input amps	8.6	13.9	17.6	24.7
Outdoor Fan Motor	Full load amps	2.6	2.6	2.6	2.6

CONTROLS

S40 Smart Wi-Fi Thermostat	22V24	•	•	•	•
E30 Smart Wi-Fi Thermostat	20A65	•	•	•	•
⁴ Discharge Air Temperature Sensor	88K38	•	•	•	•

OPTIONAL ACCESSORIES - ORDER SEPARATELY

Freezestat	3/8 in. tubing	93G35	•	•	•	•
Indoor Blower Off Delay Relay		58M81	•	•	•	•
Refrigerant Line Sets (Liq. x Suc. OD x Insulation Thickness - Length)	3/8 x 3/4 x 3/8 - 20 ft.	89J56				
	3/8 x 3/4 x 3/8 - 30 ft.	89J57	•			
	3/8 x 3/4 x 3/8 - 40 ft.	89J58				
	3/8 x 3/4 x 3/8 - 50 ft.	89J59				
	3/8 x 7/8 x 3/8 - 30 ft.	89J60				
	3/8 x 7/8 x 3/8 - 40 ft.	89J61		•	•	
	3/8 x 7/8 x 3/8 - 50 ft.	89J62				
	3/8 x 1-1/8 x 3/8 - 30 ft.	X0570				•
	3/8 x 1-1/8 x 3/8 - 50 ft.	73P91				
Snow Guard	39-1/2 X 35-5/8 in.	Y1033	•	•	•	•

NOTE - Extremes of operating range are plus 10% and minus 5% of line voltage.

¹ Refrigerant charge sufficient for 15 ft. length of refrigerant lines. For longer line set requirements see the Installation Instructions for information about line set length and additional refrigerant charge required.

² HACR type breaker or fuse.

³ Refer to National or Canadian Electrical Code manual to determine wire, fuse and disconnect size requirements.

⁴ Used with the S40 Smart Wi-Fi Thermostat for optional service diagnostics.

SOUND DATA

1 Unit Model	Octave Band Sound Power Levels dBA, re 10 ⁻¹² Watts Center Frequency - HZ							1 Sound Rating Number (dBA)	2 Estimated Sound Pressure Level at Distance From Unit (dBA at distance in ft.)				
	125	250	500	1000	2000	4000	8000		3	5	10	15	50
024 Min.	51	54.5	56.5	54	50	49	52	62	55	50	44	41	30
024 Max.	54	63.5	63	65	61.5	61	56.5	70	63	58	52	49	38
036 Min.	51.5	52.5	54	55.5	50.5	48.5	51.5	61	54	49	43	40	29
036 Max.	55	62.5	67.5	67.5	65.5	65	59.5	73	66	61	55	52	41
048 Min.	53	56	60.5	57.5	54	47	39	69	62	57	51	48	37
048 Max.	54.5	60	65.5	66	62	62	62	71	66	61	55	52	41
060 Min.	52	54.5	58.5	55.5	52	48.5	50	63	56	51	45	42	31
060 Max.	58	69.5	70.5	70.5	67	61.5	55.5	76	61	57	51	48	37

NOTE - The octave sound power data does not include tonal correction.

¹ Tested according to AHRI Standard 270-2008 test conditions. Sound rating Number is the overall A-Weighted Sound Power Level (L_{WA}), dBA (100 Hz to 10,000 Hz).

² Estimated sound pressure level at distance based on AHRI Standard 275-2010 method for equipment located on the ground, roof, or on side of building wall with no adjacent reflective surface within 9.8 feet. Sound pressure levels will increase based on changes to assumptions. For other applications, refer to AHRI Standard 275.

FIELD WIRING

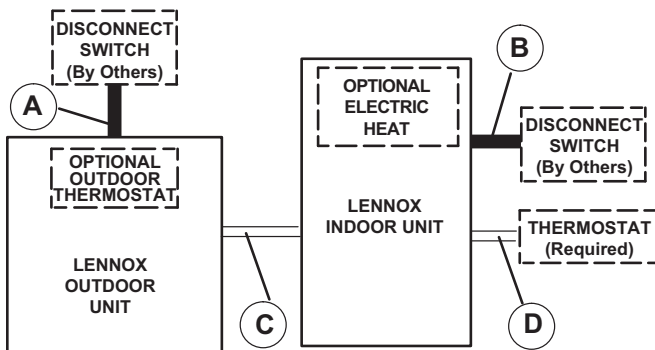

A- Two Wire Power

B- Two or Three Wire Power (size to heater capacity)

C - Lennox® Communicating Thermostat:

- Four Wire, 18AWG (RSBus)

C - Conventional Thermostat:

- Eight Wire Low Voltage, 18AWG

- Ten Wire Low Voltage, 18AWG with Optional Outdoor Thermostat

D - Lennox® Communicating Thermostat:

- Four Wire, 18 to 22AWG (RSGBus) standard thermostat cable for terminals (R, C, I+, I-).

D - Conventional Thermostat:

- Twelve Wire Low Voltage, 18AWG

- Fourteen Wire Low Voltage, 18AWG with Optional Outdoor Thermostat

NOTE - All wiring must conform to NEC or CEC and local electrical codes.

NOTE - Refer to the S40 Installation Instructions for optional wiring connections for communicating thermostats.

NOTE - Field wiring is not furnished.

INSTALLATION CLEARANCES

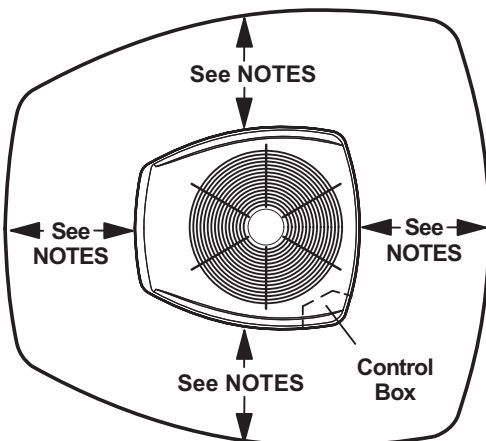

NOTES:

Service clearance of 30 in. (762 mm) must be maintained on one of the sides adjacent to the control box.

Clearance to one of the other three sides must be 36 in. (914 mm)

Clearance to one of the remaining two sides may be 12 in. (305 mm) and the final side may be 6 in. (152 mm).

A clearance of 24 in. (610 mm) must be maintained between two units.

48 in. (1219 mm) clearance required on top of unit.

DIMENSIONS - UNIT

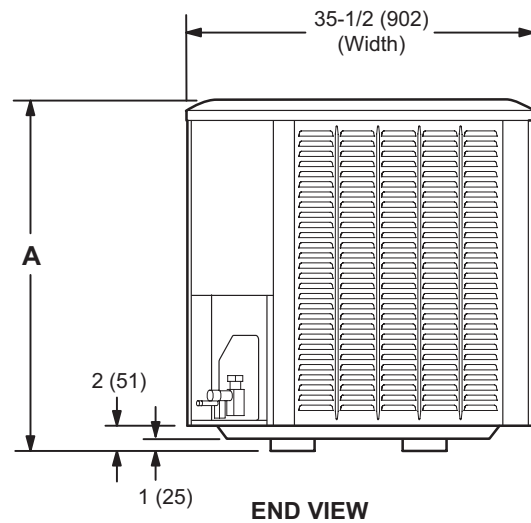
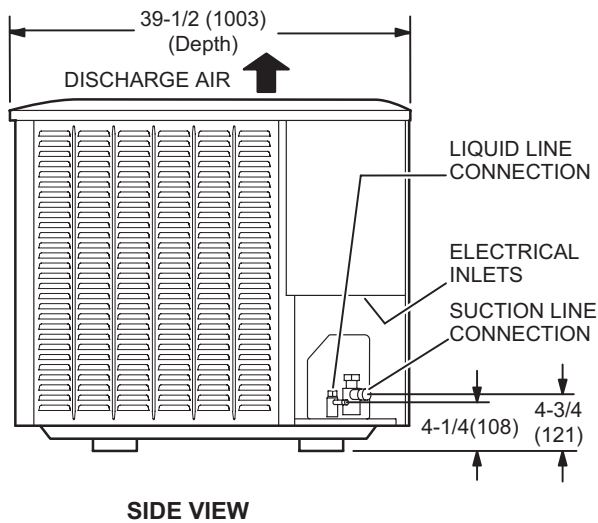
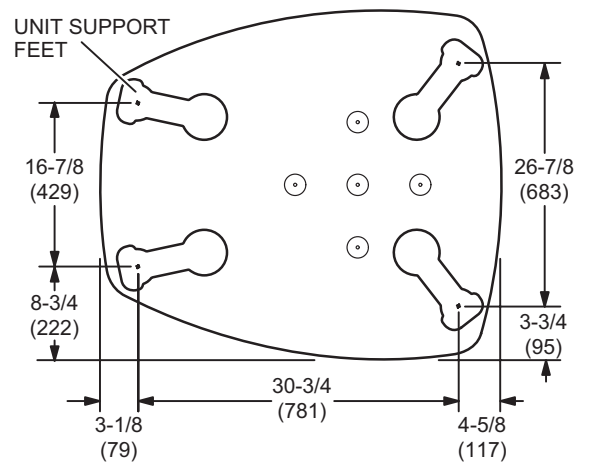
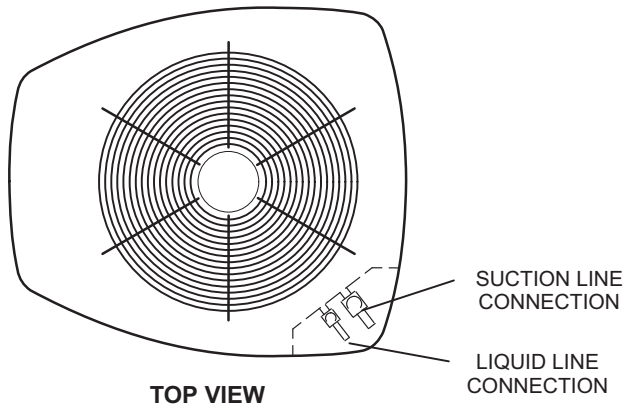

Model No.	A (Height)	
	in.	mm
EL22XPV-024	39	991
EL22XPV-036	39	991
EL22XPV-048	45	1143
EL22XPV-060	45	1143

TXV USAGE

Use this table for C35, CH23 and CR33 Field Installed TXV Match-Ups

Model No.	Order No.
EL22XPV-024	12J18
EL22XPV-036	12J19
EL22XPV-048	12J20
EL22XPV-060	12J20

CX35 and CHX35 coils and all Lennox air handlers are shipped with a factory installed TXV. In most cases, no change out of the valve is needed.

If a change out is required it will be listed in the "TXV SUBSTITUTION" table. The correct TXV must be ordered separately and field installed.

C35 coils - Replace the factory installed RFC orifice with the expansion valve listed.

CR33 and CH23 coils - Use the expansion valve listed.

AHRI STANDARD 210/240-2023

Standard Ratings relating to cooling or heating capacities shall be net values, including the effects of circulating-fan heat, but not including supplementary electric heat. Power input used for calculating efficiency shall be the Total Power.

Standard Ratings of units which do not have indoor air-circulating fans furnished as part of the model, i.e., Coil-only System, shall be established by subtracting from the total cooling capacity 1,505 Btu/h per 1,000 SCFM, and by adding the same amount to the heating capacity for non-mobile-home, non-Space Constrained units. Total Power for both heating and cooling shall be increased by 441 W per 1,000 SCFM of indoor air circulated.

TXV SUBSTITUTION

A general guide for replacing the factory installed TXV if the indoor unit (coil/air handler) is larger or smaller than the outdoor unit.

Outdoor Unit		Indoor Unit		TXV Furnished	TXV Replacement
Size	Tons	Size	Tons		
024	2	42	3.5	12J20	12J18
024	2	48	4	12J20	12J18
024	2	49	4	12J20	12J18
024	2	50/60	5	12J20	12J18
024	2	51/61	5	12J20	12J18
024	2	60	5	12J20	12J18
036	3	24	2	12J18	12J19
036	3	30	2.5	12J18	12J19
048	4	30/36	2.5/3	12J19	12J20
048	4	36	3	12J19	12J20

TXV Ranges:

12J18 - 1.5 to 2.5 ton systems - Use on 2.5 ton (030) and lower systems.

12J19 - 3 ton systems - Use down to 2 ton (024) systems.

12J20 - 3.5 to 5 ton systems - Use down to 3 ton (036) systems.

REVISIONS

Sections	Description of Change
Features	Removed optional "Low Ambient Cut-off Switch" description (not an option).



Visit us at www.Lennox.com

For the latest technical information, www.LennoxPros.com

Contact us at 1-800-9-LENNOX

NOTE - Due to Lennox' ongoing commitment to quality, Specifications, Ratings and Dimensions subject to change without notice and without incurring liability. Improper installation, adjustment, alteration, service or maintenance can cause property damage or personal injury. Installation and service must be performed by a qualified installer and servicing agency.

©2023 Lennox Industries, Inc.